

*WAR DEPARTMENT TECHNICAL MANUAL*

*TM 11-330*

THIS MANUAL supersedes TM 11-330, 20 June 1941, including C1, 23 January 1942, and section II, Training Circular No. 64, War Department, 1942

---

# SWITCHBOARDS

BD-71,

BD-72,

BD-72-A,

AND BD-72-B

---



*WAR DEPARTMENT • 29 OCTOBER 1943*

---

UNITED STATES GOVERNMENT PRINTING OFFICE  
WASHINGTON, 1943

## TABLE OF CONTENTS

---

SECTION I. Description:	Paragraph	Page
Use.....	1	1
Characteristics .....	2	1
Components.....	3	1
Weight and dimensions.....	4	5
II. Installation and operation.		
To set up switchboard.....	5	5
Preliminary tests.....	6	7
Line connections.....	7	7
To install switchboards in parallel.....	8	10
Trunking between switchboards.....	9	10
Operation.....	10	11
Special installation.....	11	13
III. Functioning of parts.		
Description of circuite lements.....	12	14
Circuit description.....	13	15
IV. Maintenance.		
Care.....	14	20
Repair and replacement.....	15	20
V. Supplementary data.		
Characteristics of circuit elements.....	16	22
List of parts.....	17	23

## DESTRUCTION OF ABANDONED MATÉRIEL IN THE COMBAT ZONE

If it should become necessary to abandon this equipment, destruction should be accomplished in the following order: jacks, keys, drops, head and chest set, and generator. Demolition may be carried out by using hammers, axes, sledges, or any readily available heavy object. If time permits, destruction should be thorough and complete so that no part can be salvaged, recognized, or used for any purpose. Incendiaries, such as gasoline, oil, or wood, explosives, grenades, or shots from various arms should be utilized for this purpose if they are available. Whenever possible, parts should be buried or thrown into bodies of water so that they cannot be easily recovered.

This manual supersedes TM 11-330, 30 June 1941, including C1, 23 January 1942, and section II, Training Circular No. 64, War Department, 1942.

## *SECTION I*

### *DESCRIPTION*

---

**1. USE.** Switchboards BD-71 and BD-72 are portable, monocord, magneto-telephone switchboards for use primarily in field wire systems. The use of the term "Switchboard BD-72" in this manual will include the Switchboards BD-72-A (order No. 88-NY-42) and BD-72-B (order No. 87-NY-42). Specific mention of the Switchboards BD-72-A and BD-72-B may occur in this manual. There are only minor manufacturing differences between the three models of the Switchboards BD-72, BD-72-A, and BD-72-B.

**2. CHARACTERISTICS.** The capacity of the BD-71 is 6 lines and that of the BD-72 is 12 lines; the BD-72 is therefore longer and heavier. Except for the difference in the amount of line equipment, the switchboards are identical. (See figs. 1 and 2.) Each switchboard contains all the equipment necessary for terminating and switching field telephone circuits, including a line terminal strip to which incoming lines may be connected directly, and an operator's telephone set that includes head set and breast transmitter. Repeating coils are permanently installed on two line circuits of the BD-71 and on four line circuits of the BD-72, permitting these circuits to be simplex quickly for telegraph without installing additional repeating coils. Line circuits are numbered below each unit on the front of the board from left to right as one faces the board. Those units to which repeating coils are connected for simplex telegraph operation have the designation (TG) following the line number. The talking and ringing range of the operator's telephone set varies with the type of line wire used, its condition, whether it is dry or wet, and whether it is on the ground or in the air. The estimated range over wire W-110 (nonloaded) is from 14 to 22 miles. This is for two switchboards connected without intervening equipment.

### **3. COMPONENTS.**

**a. General.** All elements of the switchboard are contained in a strong plywood case having carrying handles, an adjustable carrying strap, and four collapsible steel legs. The case is divided into three

compartments which are accessible from the front, top, and rear, respectively. The front or operating compartment contains the operating equipment, including the switchboard units, cords, operator's telephone with head and chest set, lights, and switches for the lights and for the night alarm. The switchboard is equipped with a small d-c bell for a

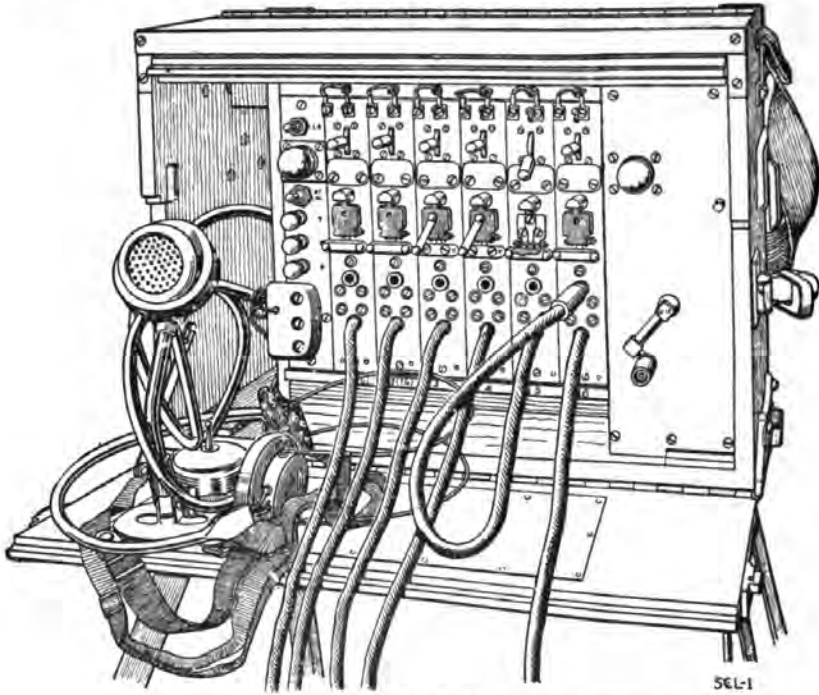

Figure 1.—Switchboard BD-71—front view, open.

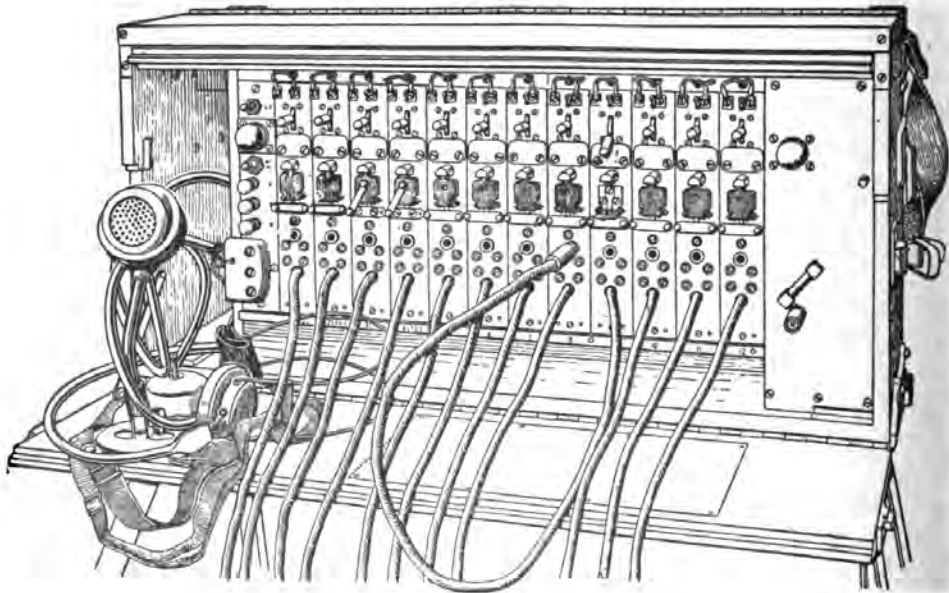

Figure 2.—Switchboard BD-72—front view, open.

night alarm. The lights on each side of the switchboard panel furnish illumination for night operation. The cover of the front compartment is in two parts; an upper panel which may be used as a rain or sun shade, and a lower panel which may be used as a writing shelf. Fastened to the lower panel is a sheet of white pyrolin which furnishes an erasable writing surface for traffic diagrams or other data. (See figs. 1 and 2.) The top or terminal compartment contains the binding posts for connection of the incoming wire lines, the telegraph leads of simplex circuits, and the ground wire. The rear compartment contains the repeating coils, six Batteries BA-30 in use and six spare, the multiple terminal strip for connecting

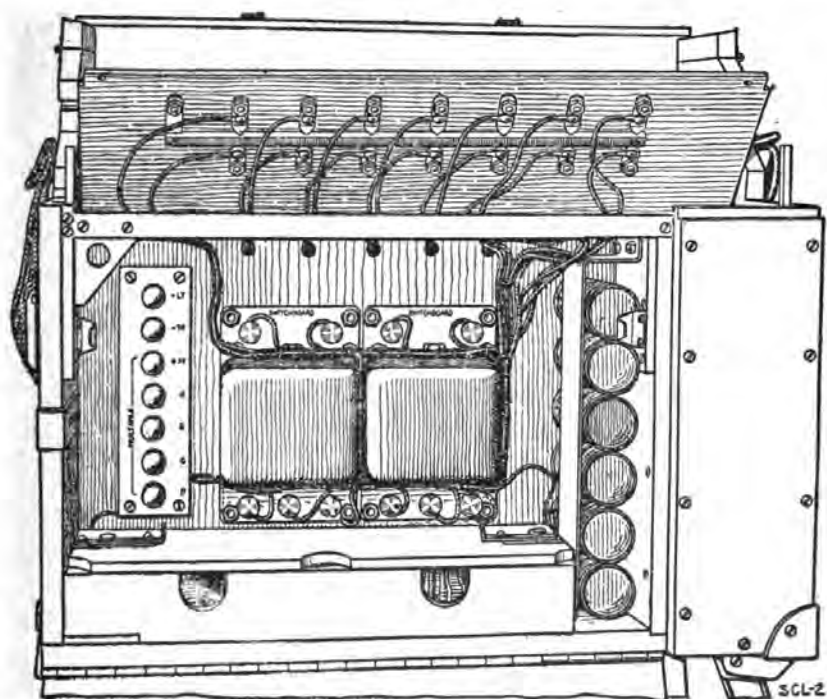

Figure 3.—Switchboard BD-71—rear view, open.

external batteries and/or a second switchboard in parallel, and a wiring diagram of the switchboard. (See figs. 3 and 4.)

**b. Operator's Head and Chest Set.** Either one of two standard types of head and chest sets may be issued with Switchboard BD-71 or BD-72.

(1) Head and Chest Set HS-19 is illustrated in figures 1 and 2. It consists of a transmitter unit and one receiver with headband.

(2) Head Set HS-30-( ) is issued for use with the helmet. (See fig. 5.) Inserts which are of a soft material are designed to fit into the ear and are fitted to the two receivers of the head set. When worn properly the receiver holders of the headband are in front of the ears. The headband is of relatively soft steel and can be bent to fit the contour of the operator's head. If fitted correctly in the region where the sweatband of the helmet

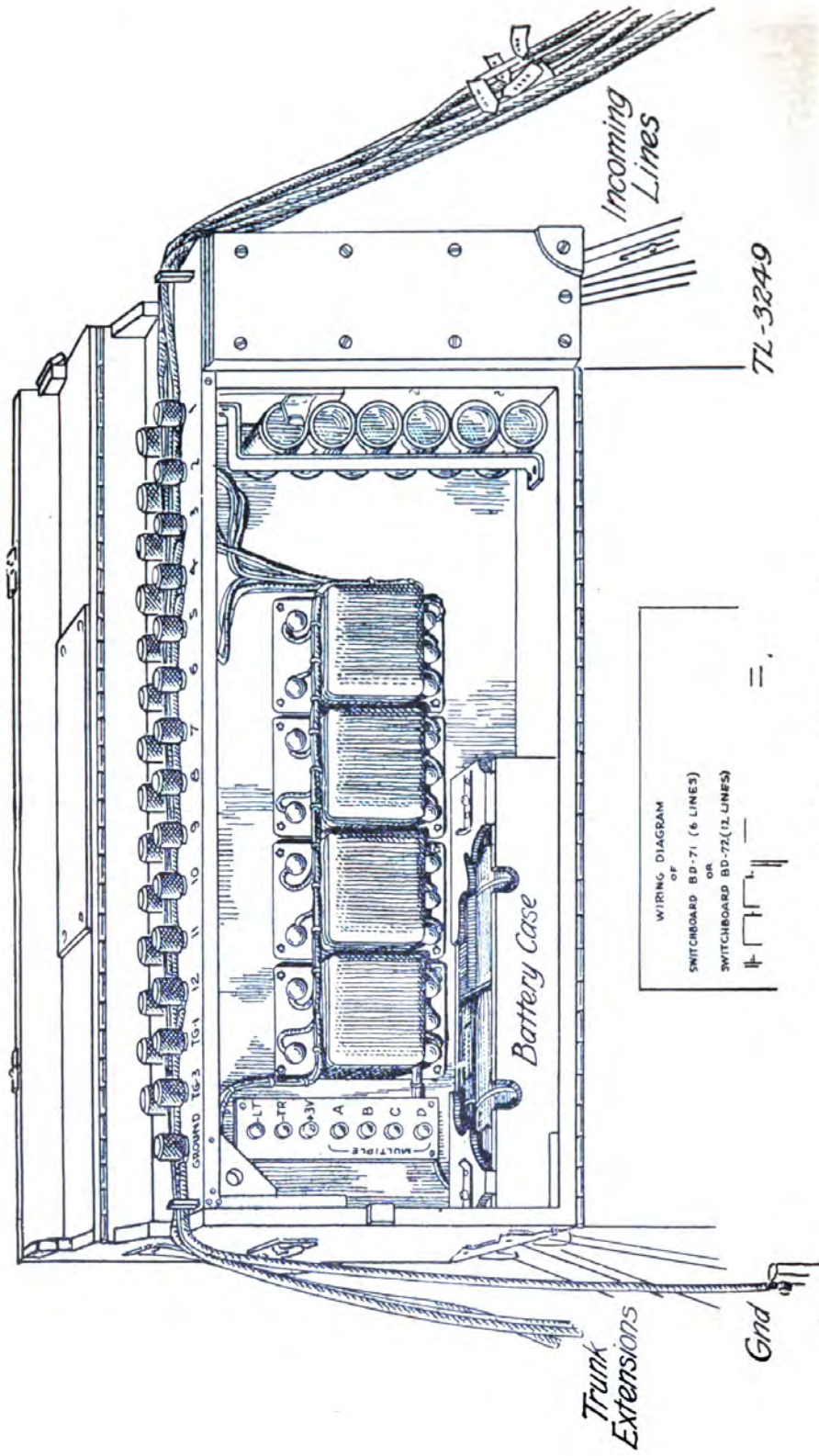

Figure 4.—Switchboard BD-72—rear view, open.

will set, there will be enough tension from the steel headband to assure a partial seal against outside noises, and the helmet will not exert any uncomfortable pressure. A clip, which fastens to the clothing, is provided to support the weight of the cord. In fastening the clip, enough slack must be allowed to permit free movement of the head.

**4. WEIGHT AND DIMENSIONS.** Switchboard BD-71 complete, including a head and chest set and one spare cord but without batteries, weighs approximately 58 pounds packed. The over-all dimensions are  $18\frac{1}{2} \times 10\frac{1}{4} \times 15$  inches and it has a displacement of  $1\frac{1}{2}$  cubic feet. Switchboard BD-72 weighs approximately 81 pounds complete, not including batteries, and its over-all dimensions are  $27 \times 10\frac{1}{4} \times 15$  inches, displacing 2 cubic feet. The height of the writing shelf above ground for either board, with the legs fully extended, is 24 inches.

## SECTION II

### INSTALLATION AND OPERATION

---

#### **5. TO SET UP SWITCHBOARD (fig. 7).**

**a. Legs.** Place the switchboard on its side, unlock the legs one at a time by pressing the spring release button and pulling back slightly. The legs can then be unfolded. Set the switchboard upright on its four legs. To extend the legs to the desired length, raise one end of the switchboard, press the spring release button on each leg, and push forward. This will extend the telescope leg to its full length. Repeat this performance on the opposite end of the switchboard, adjusting the legs so that they rest firmly on the ground. If the switchboard is to be placed on a table or similar support, leave the legs folded and locked in place.

**b. Compartments.** Open the operating (front) compartment and hook the lower panel in place horizontally as a desk and writing surface. Push the upper panel back into the recess beneath the top of the case or adjust it so that it will serve as a rain or sun shade if desired. Pull out the cords from under the switchboard units and allow them to hang down freely in front of the shelf. The plugs should be clear of the ground so as not to collect dirt which might be introduced into the jacks when the plugs are used. Restore to their horizontal position the spring locking bars that hold the drop shutters in place while the switchboard is in transport. The face of the switchboard should be vertical or tilted slightly forward so that the shutters will fall of their own weight when released. Open the rear compartment and place two Batteries BA-30 *in series* in the right-hand side of the battery case (facing the back of the switchboard), and two pairs of Batteries BA-30 in the left-hand side of the case (see fig. 4).

Each pair of batteries must be in series, that is, the top (positive) terminal of one battery in contact with the base (negative) terminal of the other. The base of one battery of each pair should make contact with the spiral spring at one end of the case and the top terminal of the other battery should make contact with the metal plate in the center of the case. The two batteries in the right-hand side of the case (facing the back of the switchboard) are for the operator's telephone. The remaining batteries are for the night-alarm bell and the lights. If Batteries BA-30 are not available, you can use any suitable 3-volt direct-current source by connecting the positive lead to the binding post marked + 3V, and the negative lead to the two binding posts marked — LT and — TR on the multiple terminal strip above the battery box. The connection should be such that the two negative binding posts are strapped together.

**c. Head and Chest Set.** Put on and adjust the head and chest set, insert its plug into the jack panel (to the left of the switchboard units), and operate the toggle switch on the chest unit to the ON position to close the transmitter circuit. If the head and chest set has no suitable plug, you can connect the leads from transmitter and receiver to the three binding posts, marked T, C, and R, directly above the jack. In an emergency, or if desired for training purposes, any suitable transmitter and receiver, such as the handset of a field telephone, may be used in this manner.

NOTE.—This procedure is the same for either Head and Chest Set HS-19 (see fig. 1) or HS-30-( ) and TD-1 (see fig. 5).

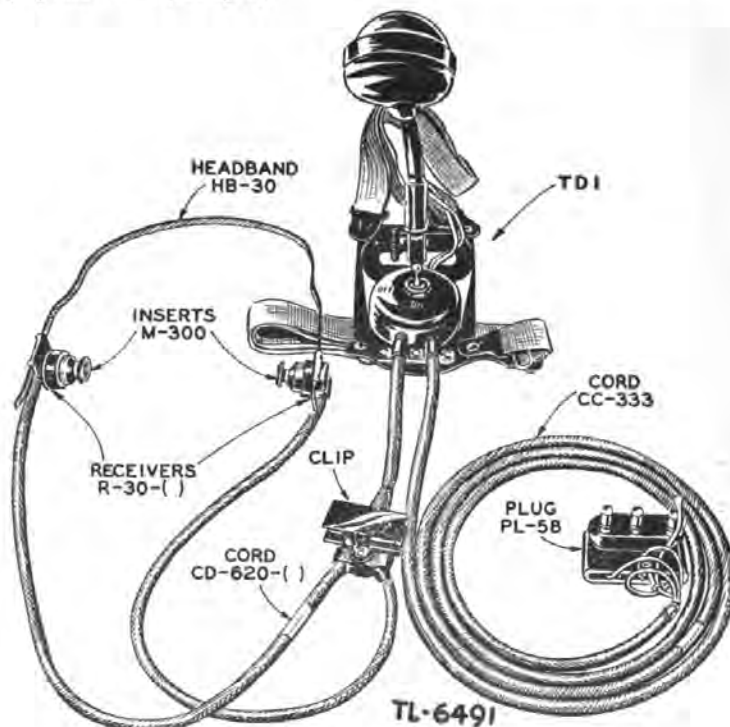

Figure 5.— Head Set HS-30-( ) and Chest Set TD-1.

## 6. PRELIMINARY TESTS.

**a. Operator's Set. (1) Generator Circuit.** Select any switchboard unit and see that the line terminals in the terminal compartment which correspond to this unit are clear. Raise the key of this unit, and while holding it in the RING position (up), turn the generator crank on the telephone panel (to the right of the switchboard units) rapidly for several turns. It should turn easily. Short-circuit the line terminals of the same unit, raise the key, and turn the generator again. It should turn hard, as if a drag had been placed upon it.

**(2) Transmitting and Receiving Circuit.** Blow lightly and steadily into the transmitter while alternately depressing the key of any unit to the TALK position (down) and restoring it to normal. You should hear the sound (sidetone) strongly in the receiver while the key is depressed but not when it is restored to the normal position

**b. Switchboard Units.** Connect a serviceable field telephone to the line terminals of the first switchboard unit. Operate the night-alarm (NT AL) toggle switch, located on the jack panel to the left of the switchboard units, by pushing the switch to the right. Turn the generator of the test telephone. The shutter of the unit should fall and close the circuit to the night-alarm bell, which should start ringing. Restore the shutter, which should stop the ringing. Raise the key of the unit and ring into the test telephone by turning the generator of the switchboard. This should operate the buzzer (or bell) of the test telephone. Depress the key of the unit to the TALK position and talk and listen from the switchboard to another man at the test telephone. Each voice should be heard clearly in the other receiver. Test each unit of the switchboard in a similar manner by connecting the test telephone to each pair of line terminals in turn and repeating the foregoing test.

**c. Lights.** The lamp on each side of the switchboard units should light when the lamp toggle switch (LA) is pushed to the right. The reflectors may be adjusted by turning them so that they focus the light across the designation strips of the switchboard units. To conserve batteries, use the lights only when necessary.

## 7. LINE CONNECTIONS.

**a. Terminals.** In the terminal compartment, each pair of binding posts for the line wires is numbered to correspond with the switchboard unit to which it is connected. These numbers run from right to left when the back of the board (see fig. 4) is faced. At the left of the line terminals are similar binding posts for the telegraph legs, marked TG 1, TG 2, TG 3, and TG 4, which are connected to the center tap on the line side of the repeating coil in the line circuit to which it is connected. The last binding post on the left marked GROUND is for the ground connection for the switchboard only. A metal bar connected to this terminal runs along the under side of the terminal strip underneath the two rows of binding

posts, furnishing an air spark-gap to ground between the metal bar and the base of each binding post for protection against lightning. (See fig. 6.)

**b. Terminating Local Circuits.** Connect the line wires of the trunk and local circuits entering the switchboard and the telegraph legs of simplex circuits, if used, to the binding posts in the terminal (top) compartment. Tie them to a support in such a way that a drip loop is provided to prevent rain from running down the wire into the switchboard and so that there is no strain on the terminal connections. Attach tags showing the circuit designation to the wires close to the switchboard. The wires may enter the terminal compartment from either end. Remove about  $\frac{3}{4}$  inch of insulation from the wire, leaving 1 inch of insulation on the end to prevent the wire from untwisting. Place the bared part of the wire in the binding post slot and turn down the head tightly with the fingers. *Caution: Do not use pliers.*

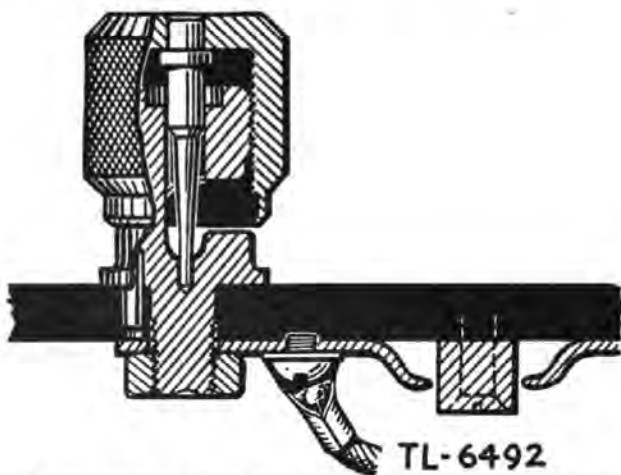

Figure 6.—Cross-section of Binding Post TM-175 and air spark-gap protector.

**c. Terminating Trunk Circuits.** Since trunk circuits often are extended along the axis of communication, it may be desirable to have the wires of all trunk lines enter the terminal compartment at one end and extend through the switchboard, with about 3 feet being allowed to hang freely from the opposite end. (See fig. 7.) When the extended lines have been run and tested and are known to be free from trouble, they can be spliced onto the 3-foot extensions without disconnecting the circuits from the switchboard. After the forward switchboard takes over operations, the trunk lines are removed from the binding posts and the bared portions of the wires taped. Continuity of communication is maintained by doing this.

**d. Grounds.** A ground wire should be run from the ground binding post to a suitable ground rod or other buried metallic body with a large area of contact with the earth. Since most of the installations of this switchboard will be in the field away from water pipes and similar good grounds, ground rods are necessary equipment. Because the lowest

possible resistance to ground is essential for protection, care must be exercised in driving the rods to their full length and preserving a firm close contact between the rod and the soil. The tendency of the rod to whip when being driven will be reduced by using a small hammer or hand ax. In selecting the location for the ground rod, select the dampest or most moist site available. The installation need not be immediately adjacent to the switchboard, provided the wire connection does not appreciably increase the resistance of the ground connection. Be sure that the rod to be used is free from all paint or grease and that the ground wire can be securely fastened to the rod.



Figure 7.—Switchboard BD-72 set up for operation, showing terminal compartment open.

**e. Separation of Trunks and Locals.** In general, connect trunk circuits to the lower numbered line terminals on the switchboard. Connect trunk circuits over which it is desired to operate simplex telegraph circuits to lines 1 and 2 on the 6-line switchboard or to lines 1, 2, 3, and 4 on the 12-line switchboard, since these are the lines in which repeating coils have been connected. Connect local circuits to the higher numbered terminals at the other end of the switchboard. This makes it easier to distinguish between trunk and local calls.

**f. Wire Arrangement.** Arrange all wires so that they lie behind the metal corner posts on each end of the compartment. Close the cover while holding the sides open. The partially opened sides provide ample

clearance so that the cover may be completely closed and latched with the wires in place.

**g. Circuit Designation.** The designation of each circuit, that is, the code name of the central or installation or the number of the local telephone to which the unit is connected, should be entered in pencil on the designation strip just below the key of each unit. The drop shutters of units which are not to be used should be locked in the UP position by the spring locking bars.

**8. TO INSTALL SWITCHBOARDS IN PARALLEL.** To obtain additional line capacity, an auxiliary BD-71 may be connected in parallel with either a BD-71 or BD-72, and the combination can be operated as a single switchboard, using the operator's telephone set of *only one* of the switchboards. Place batteries in switchboard to which the operator's set will be connected (par. 5b). Place the switchboards adjacent to each other. If one of the switchboards is a BD-72 (12-line), it will be necessary to place them approximately at right angles to each other in order for all cords to reach a jack. It is impracticable to operate two BD-72's connected in parallel. (See par. 9 for method of trunking between switchboards.) Connect the terminals marked +3V, A, B, C, and D of the multiple terminal strip in the rear compartment of one switchboard to the similarly marked terminals in the rear compartment of the other switchboard. These connections may be made with field wire or any suitable insulated wire. Place the wires over the sponge-rubber closure at the left edge of each case before closing the cover of the compartment. The outlet provides enough clearance for all necessary wires with the cover shut and latched. Do not plug in the second head and chest set. If it is desired to use the night alarm and/or lights of the second switchboard, four BA-30's should be installed in the proper (left-hand) side of the battery case in the second switchboard. In an emergency, if extra batteries are not available, the night alarm and the lights of the second switchboard may be operated from the batteries of the first by installing an additional wire connecting the -LT terminal on each of the multiple terminal strips together. In any case, regardless of what battery is used for the night alarm and lights of the second switchboard, the night alarm and light switches on the switchboard must be turned on in order for them to operate.

**9. TRUNKING BETWEEN SWITCHBOARDS.** When two switchboards connected in parallel are installed in a manner which prohibits the plugging in of any unit cord in all of the other unit jacks, best use may be made of the switchboards by trunking between them. This is accomplished by reserving, for trunking, one or more units on the left-hand switchboard and a like number of units, or corresponding positions, on the right-hand switchboard. Units selected should be from those not equipped with repeating coils, and each unit should be plainly marked

on the designation strip as an interposition trunk. Each interposition trunk unit on the left-hand switchboard should then be connected at the terminal strips with field wire to the corresponding interposition trunk unit on the right-hand switchboard. Any connection to be made between the two switchboards where the unit cords will not reach may then be made through these two interposition trunk units which are connected.

## 10. OPERATION.

**a. Operator's Equipment.** The operator should be seated in a comfortable position on an improvised seat in front of the switchboard so that he may observe all the switchboard drops and conveniently operate the keys and generator and handle the cords. The head and chest set should be adjusted and the toggle switch on the chest unit operated to close the transmitter circuit. This switch may be left in the operated position continuously, since no transmitting battery is used until the key of one of the units is operated.

**b. Incoming Call. (1)** An incoming call is indicated by the falling of the signal drop of the calling line, which will cause the night alarm to operate if the night-alarm switch is on. Depress the key of that unit to the TALK position (down) and answer the party (or central) calling, at the same time picking up the calling party's plug. After determining the party (or central) to be called, restore the calling party's key. Ring the called party by raising the key of that unit to the RING position (up) and turning the generator rapidly several times while holding the key in the UP position.

*Caution:* Be sure to restore the calling party's key before ringing the called party. With the calling party's key and drop shutter both down, operation of the generator will result in ringing back the calling party, which is undesirable.

**(2)** Immediately after ringing, depress the called party's key to the TALK position and, if it is a local call, immediately insert the calling party's plug into the called party's jack. If it is a trunk call, pass the call to the distant operator before making the connection. After the connection has been made, the operator's telephone is bridged across the connection, enabling him to supervise the call. The called party's key may be left down until conversation has actually begun or, in the case of a trunk call, until the call has been passed to the distant operators. When the call has been supervised, the called party's key and the calling party's drop should be restored. In case it is necessary for the operator to answer another call before he has properly supervised the first connection, he restores the key but leaves the drop down and proceeds to handle the other call. He then goes back at the first opportunity and supervises the first connection, restoring the drop after he has done so. A drop should not be restored on a connection until it has been supervised, and when left in the DOWN position, it indicates a connection that still requires

supervision. A connection that has been established and is being used is supervised by depressing the key of the called party's unit, listening, and challenging if necessary. Care should be taken that keys on two connections are never at the same time in the TALK position, as the two circuits will thus be coupled through the operator's set, resulting in cross-talk on both. After talking to either party, always restore his key before commencing any other operation.

**c. Completed Call.** When the conversation is completed and either party rings off, that is, turns the generator of his telephone, the drop of the calling party's unit will fall. The operator should depress the key and answer the signal to see if either party desires another connection.

NOTE.—This operation has been performed in figures 1 and 2. If no reply is received, take down the connection and restore the drop and key. The drop shutter of the other unit will not fall, since the drop of the unit was removed from the circuit when the plug of the calling party was inserted in the jack of that unit. In case another call is desired by either party, the operator must ascertain which party it is who desires another connection, by asking which party is calling.

**d. Conference Calls.** When a calling party requests a simultaneous connection with two or more called parties, restore the calling party's key. He may hold the line or not, as he desires. Ring the first of the called parties, depress this party's key and when he answers, advise him to hold the line for a conference call. Restore his key and insert the calling party's plug in his jack. Pick up the first called party's plug and ring the second called party. Depress this party's key, and when he answers, advise him also to hold the line for a conference call. Restore his key and then insert the first called party's plug into the second called party's jack. Extend the connection in a similar manner to each of the called parties in turn. When the last of the called parties has been connected, restore his key, depress the key of the calling party, and, if he is not already on the line, ring him. When the calling party answers, inform him that all parties are now on the line. When the conversation has begun, restore the calling party's key and drop. All parties are now bridged together (at the switchboard) so that each can talk or listen to any of the others. The drop of the calling party remains bridged across the connection for a supervisory signal as in an ordinary call. The drops of all other parties have been removed from across the connection, since the plug of the preceding party is in each jack. The connection may be supervised by depressing the key of any one of the connected units.

**e. Straight-Through Connection.** When two parties desire a straight-through connection so that either party can ring the other without operating the drops or requiring the services of the operator, the units may be cross-patched, that is, the plug of one unit inserted into the jack of the other and vice versa. This disconnects both signal drops from the circuit and provides a direct connection between the two lines.

Since neither party is then able to signal the operator, the operator should be advised as to how long the through connection is desired

**f. Night-Alarm Circuit.** The night alarm consists of a bell which rings when any drop falls and stops when the drop is restored. The night alarm may be turned on or off by the toggle switch marked NT AL on the jack panel to the left of the switchboard units. This switch is on when it is pushed to the right and off when to the left. It is not ordinarily used when an operator is at the switchboard, but should be turned on at night and at other times when it is necessary for the operator to leave the switchboard. The night lights are controlled by a similar toggle switch located on the jack panel above the left-hand light. The lights should be used only when necessary in making connections at night.

## **11. SPECIAL INSTALLATION.**

**a. Emergency Installation Employing a Field Telephone as an Operator's Set.** If the transmitting and receiving or generator circuits of the operator's telephone set should fail and cannot be repaired immediately, a field telephone may be used as an operator's set. Test the telephone to insure that it is in proper operating condition. Plug the head and chest set into the jack at the top of Telephone EE-8, EE-8-A, or EE-8-B (or connect the transmitter, receiver, and common leads to the proper corresponding binding posts on other types of telephones), and connect the spare switchboard cord furnished with the switchboard to the line binding posts of the telephone. Place the telephone flat against the right side of the switchboard with the generator handle to the front, and pass the switchboard carrying strap around it and through the loop on the leg casting. Double the strap back to the buckle and tighten it so that the telephone rests securely against the side of the switchboard and is flush with the front face, so that the generator handle can be easily rotated by the operator. The spare switchboard cord is used to connect the telephone to the jacks of the calling and called parties in turn. If no spare cord is available, field wire may be used to connect the telephone line terminals to the line terminals of one of the switchboard units at the terminal strip in the top compartment. The cord of this switchboard unit may then be used as an operator's cord.

**b. Operation When Using a Field Telephone as an Operator's Set.** When a field telephone is used in this way, the keys on the switchboard units are not used and should be left in the normal position. To answer a call, insert the operator's plug into the jack of the calling party. Determine the party to be called and then withdraw the plug and insert it into the jack of the called party. Ring the called party with the generator of the telephone and, on a local call, immediately insert the called party's plug into the calling party's jack, completing the connection. In the case of a trunk connection, do not complete the connection until

the call has been passed to the distant operator. If the telephone is connected to the line terminals of a switchboard unit, follow the same procedure, using the cord of the unit for an operator's cord. The spring locking bar should be placed over the drop shutter of the unit so used. The called party's drop remains bridged across the connection as a supervisory signal. Connections may be supervised by plugging the operator's cord into the called party's jack.

### SECTION III

## FUNCTIONING OF PARTS

---

### 12. DESCRIPTION OF CIRCUIT ELEMENTS.

**a. Operator's Telephone Set (fig. 11).** The operator's telephone set contains all the elements that are essential to an ordinary magneto telephone set, with the exception of a ringer. It includes a generator (GN-38, GN-38-A, or GN-38-B), an induction coil with three windings, one 0.5-microfarad and one 0.3 microfarad capacitor, and a varistor. The head and chest set includes a nonpositional carbon button-type transmitter and either a single or a double receiver with headband. (See figs. 1 and 5.) A two-conductor cord carries the leads from the receiver to the chest transmitter unit. The transmitter and the receiver are both connected from the chest unit to the rest of the operator's telephone set by a three-conductor cord which contains one lead from the transmitter, one from the receiver, and a common lead. This cord is connected to the jack on the jack panel to the left of the switchboard by means of a three-conductor plug. The jack contacts are brought out in parallel to binding posts directly above the jack as an alternate means of connecting a transmitter and a receiver not equipped with a suitable plug.

**b. Generator.** Switchboards BD-71 and BD-72 may be equipped with either generator GN-38, GN-38-A or GN-38-B. The generator type number is shown on the generator frame just below the driven end of the armature or rotor. Generator GN-38 was designed for use in a switchboard having an aluminum alloy chassis. Generators GN-38-A and GN-38-B were designed for those with a ferrous metal chassis. The use of a GN-38 in a switchboard having a ferrous metal chassis is *not* recommended because the signaling range of the switchboard will be reduced since the output voltage will be decreased by the magnetic field loss in the ferrous metal case surrounding the generator. If a GN-38-A or GN-38-B is used in a switchboard having an aluminum alloy chassis, the output voltage will be somewhat greater than the rated output since these generators were designed to compensate for losses in ferrous

metal cases. Such increased output gives a slight increase in signaling range and is not harmful to associated equipment.

**c. Switchboard Unit EE-2-B or EE-2-C (fig. 10).** These units are fundamentally alike and interchangeable. The differences are in the drops and jacks, newer types being used in the EE-2-C. A difference in the cranking effort required on the field telephone to ring down the drops of the two different units should not be regarded as indicating trouble on the line. This slight difference is caused by a difference in resistance of the drop windings, the EE-2-B unit having a 200-ohm winding and the EE-2-C a 500-ohm winding. The latter is more sensitive. Each unit contains all the elements necessary for terminating and switching one line; that is, line terminals, a ring-talk key, a signal drop, a jack, and a cord with plug, all properly interwired. When the unit is fitted into its position in the switchboard panel, electrical contacts are made at the top, center, and bottom with three bus bars which run the length of the switchboard panel behind the units. There are two additional bus bars just above the bottom bus bar, to which two flexible leads from each unit are connected by screws. The operator's telephone set, batteries, and night alarm are connected to the bus bars at the ends, the necessary common connections from these elements being made in this way to all units through the bus bars. The line terminals at the top of each unit are wired to the proper line binding posts on the line terminal strip in the terminal compartment. This wiring includes a repeating coil on lines 1 and 2 of the 6-line switchboard and on lines 1, 2, 3, and 4 of the 12-line switchboard.

**d. Night Alarm.** The night-alarm bell is in series with the NT AL switch and with the night-alarm and lamp battery (3 volts). Contacts on each unit, operated by the drop shutter, close the night-alarm circuit whenever the shutter of that unit falls. With the NT AL switch operated, when any shutter falls, the circuit is completed and the bell rings. Restoring the shutter or operating the NT AL switch to the OFF position will open the circuit and stop the bell.

**e. Lights.** The two switchboard lights are in parallel and connected in series with the light switch and the light battery (3 volts). The circuit for the lights is independent of any contacts or switch except the light switch, and the lights may be turned on or off as desired.

**f. Multiple Terminal Strip.** Connections from the bus bars, operator's telephone, and the batteries are brought out to binding posts on the multiple terminal strip in the rear compartment so that these connections may be readily extended to another switchboard for operation in parallel. External batteries may be connected to this multiple strip.

### **13. CIRCUIT DESCRIPTION (figs. 8 and 9).**

**a. Operator's Telephone. (1) Transmitting Circuit. (a)**  
The induction coil, capacitors, transmitter, and receiver are connected

in an antisidetone circuit in which the impedance of these elements and the characteristic impedance of the average line are so balanced as to reduce the sidetone in the operator's receiver to the proper level. This results in an effective receiving gain, since the effect of noise in the vicinity of the switchboard is reduced. The operator also unconsciously speaks louder into the transmitter when he does not hear his own voice loudly in his receiver. This results in an effective transmitting gain. On lines shorter than the average, the sidetone is more pronounced and the antisidetone effect lessened.

**(b)** The induction coil is an autotransformer with three windings. The primary (2-3) winding is in series with the transmitter and transmitter battery. Contacts on the key of each switch board unit, operated when the key is depressed to the talk position, close the primary circuit. The primary winding is of very low resistance (three ohms) so that high changes in current are produced by the transmitter when it is activated by speaking into it.

**(c)** The second (1-2) winding is in series with the primary winding, the third (3-4) winding, the 0.3-microfarad capacitor, and the 0.5-microfarad capacitor. When the key of any unit is depressed to the talk position, closing the primary circuit as indicated above, other contacts on the key connect this secondary circuit to the line at the same time. The relative inductances of the windings of the coil are such that the impedance of the primary circuit will match the impedance of the secondary circuit to provide maximum transfer of energy. The receiver is bridged across the third (3-4) winding and the 0.3-microfarad capacitor in series. A network is thus formed in which the impedance of the third winding and 0.3-microfarad capacitor is balanced against the impedance of the primary and secondary windings, the 0.5-microfarad capacitor, and the characteristic impedance of the average line in such a manner that the receiver is across points of nearly equal potential, and only a small amount of the current induced in the secondary circuit by the local transmitter will flow through the local receiver.

**(2) Receiving Circuit.** **(a)** The receiver is in series with the primary and secondary windings and the 0.5-microfarad capacitor. The impedance of this secondary circuit matches the characteristic impedance of the average line using W-110 for maximum transfer of energy from line to receiver. The third winding and 0.3-microfarad capacitor in series are bridged across the receiver, forming a balancing network. The incoming voice currents tend to flow through this balancing network, but current is induced in the opposite direction in the third winding from the primary and secondary windings. This results in only a small amount of current in the balancing network, most of the incoming current going through the receiver.

**(b)** The 0.5-microfarad capacitor is placed in series with the receiver to prevent the flow of direct current from the primary circuit through the

receiver. It also minimizes the ringing current received in the operator's receiver in the case of an incoming ring while this telephone is connected to a line.

(c) The varistor consists of two parallel opposing arms, each consisting of three copper-oxide disks. It is bridged across the operator's receiver to reduce clicks caused by electrical disturbances in the connected circuit.

**(3) Ringing Circuit.** The generator has a spring contact which in normal position forms a part of the night-alarm circuit. When the handle of the generator is turned, this contact is broken mechanically,

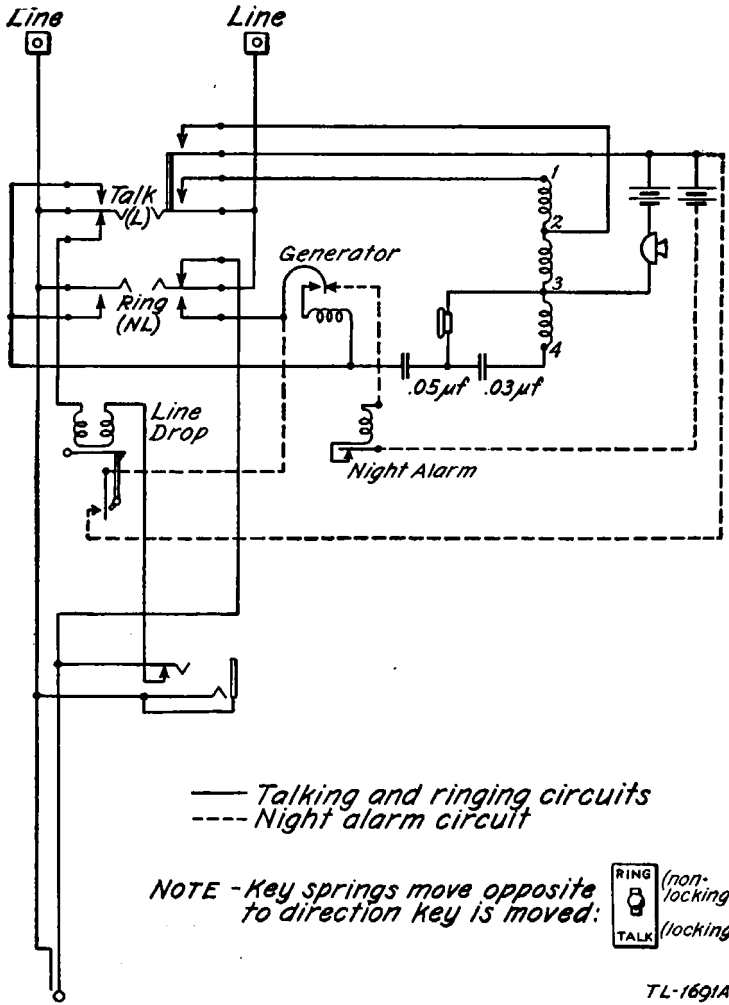

Figure 8.—Switchboard Unit EE-2-B with operator's set and night alarm—schematic diagram.

and another contact is made which places the output of the generator across any line through contacts on the key of the switchboard unit pertaining to that line when the key is raised to the ring position. The output of the generator is about 100 volts at 16 to 20 cycles per second.

**b. Switchboard Unit EE-2-B or EE-2-C. (1) Signaling Circuit.** With the key of any unit in the normal position, the windings of the drop, in series with a normally made contact on the tip side of the jack, are across

the line to which the unit is connected. The cord of the unit is in parallel with the jack. Incoming ringing current from the line passes through normally made contacts on the key, the contact on the jack, and through the windings of the drop, causing the armature to vibrate. This releases the drop shutter which falls of its own weight. When the shutter is down, it closes a contact, so that if the night-alarm switch is on, the night-alarm circuit is completed, causing the night-alarm bell to ring. The drop latch and armature may be adjusted by means of a setscrew in the rear of the unit.

**(2) Operator's Circuit.** When the key of the unit is depressed to the TALK position, contacts on the key close the primary circuit of the operator's telephone, and place the secondary circuit across the line so that the operator can talk and listen to the calling party. At the same time, the calling party's drop is removed from across the line by a break contact of the key. The line circuit is completed as far as the tip and sleeve of the plug by a normally made contact on the ring side of the key. The calling party's key should be restored as soon as the identity of the party to be called is determined.

**(3) Line Circuit.** When the calling party's plug is inserted in the called party's jack, the tip and sleeve of the plug make contact with the tip and sleeve of the called party's jack, extending the line circuit to the called party's line through a normally made contact on the key of the called party's unit. The called party's drop is disconnected by the mechanical breaking of the circuit at the contact on the tip spring of the jack when the plug is inserted in the jack.

**(4) Generator Circuit.** When the operator raises the key of the called party's unit and rings, the generator of the operator's telephone is placed directly across the called party's line, the ringing current passing through the make contacts of the key and over the line of the called party's telephone. A break contact on the key opens the line circuit back to the calling party's line and also removes all elements of the operator's telephone, with the exception of the generator, from across the line, so that the ringing current goes only to the called party's instrument. (See *Caution* in par. 10b (1).)

**(5) Supervisory Circuit.** After the called party has been rung, the called party's key is operated to the TALK position. The lines of the calling and called parties are now directly connected by the calling party's cord. The operator's telephone is bridged across the connection by *make* contacts on the called party's key, enabling the operator to talk or listen to either party as long as the key is operated. When the operator restores the called party's key to normal after having supervised the connection, the operator's telephone is removed from the line. The calling party's drop is then restored and left bridged across the connection for a supervisory signal. When either party rings off, the ringing current will operate the calling party's drop, indicating to the operator that the conversation is finished



## SECTION IV

### MAINTENANCE

---

#### 14. CARE.

a. When a switchboard is removed from service, batteries may be left in place if the switchboard is to be put into service again within 24 hours. If the switchboard is to remain out of service for a period greater than 24 hours, remove the batteries in the battery case. If this is not done, there is danger of immediate damage to operating parts by corrosive seepage from the batteries.

b. Do not allow dirt to accumulate on any part of the equipment. Terminals particularly should be kept clean; likewise the air gap to the ground strip underneath the line terminals. Keep all mounting screws and wire connections tight. Protect the switchboards from the elements as far as practicable, and store them only in a dry place. Do not attempt field repairs beyond the replacement of batteries or of defective switchboard units or parts, and the checking of loose or broken connections.

#### 15. REPAIR AND REPLACEMENT.

a. If inspection or tests indicate faults, proceed cautiously to determine the nature of the trouble before attempting any disassembly. When elements do not function, or function improperly, the cause will usually be found to be loose or broken connections. All equipment is accessible either directly or by removal of the screws holding it in place. All elements are incorporated in such a manner as to facilitate ordinary adjustments, repair, or replacement. Spare switchboard units should be available for replacement by using personnel. Defective units or parts which cannot readily be adjusted or repaired should be removed and turned in for repair.

b. Individual switchboard units may be removed for inspection by disconnecting the two line leads at the top, and taking out the screws at the top and bottom of the unit. Complete removal requires disconnection of the two remaining leads from the bus bars within the frame of the switchboard. (See fig. 10.) In replacing a unit, be sure to reconnect properly; the yellow-green lead going to the top (or right-hand) screw, and the yellow lead going to the bottom (or left-hand) screw.

c. The telephone panel at the right of the switchboard units may be removed by taking out the screws at the top and the bottom. The elements of the telephone set are wired to the other parts of the switchboard by means of a flexible cable. (See fig. 11.) Defective elements may be removed individually by disconnecting the leads. In removing the generator, care should be taken to retain and replace the bakelite

washers and insulating strip, as they are necessary to insulate the generator from the frame of the panel to keep it from grounding. Replace a defective generator with another of the same model, GN-38, GN-38-A, or GN-38-B if possible (see par. 12b). Replacement with a different model may reduce the ringing range of the switchboard.

d. The jack panel at the left of the switchboard units likewise may be removed for inspection and replacement if necessary. (See fig. 12.)

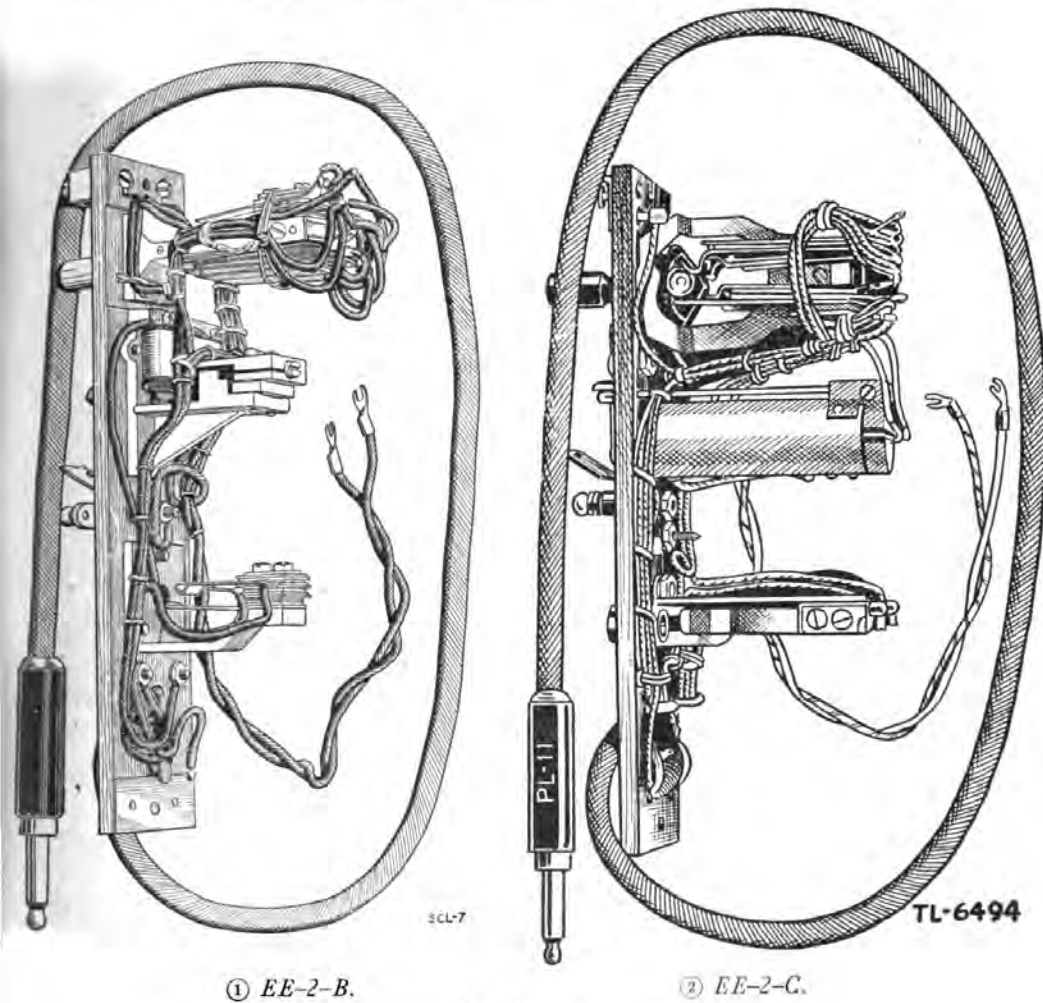

Figure 10.—Switchboard units.

e. The lamps are the usual two-cell flashlight type and are easily removed and replaced by pulling out the lamp cap and unscrewing the lamp from the socket. Repeating coils in the rear compartment may be removed by disconnecting the leads and removing the four nuts holding the coil in place. If the coil is not to be immediately replaced, the switchboard unit with which it was associated may be made available for use as an ordinary line circuit by connecting the yellow leads which were removed from the line side of the repeating coil to the brown leads which were removed from the switchboard side of the coil.

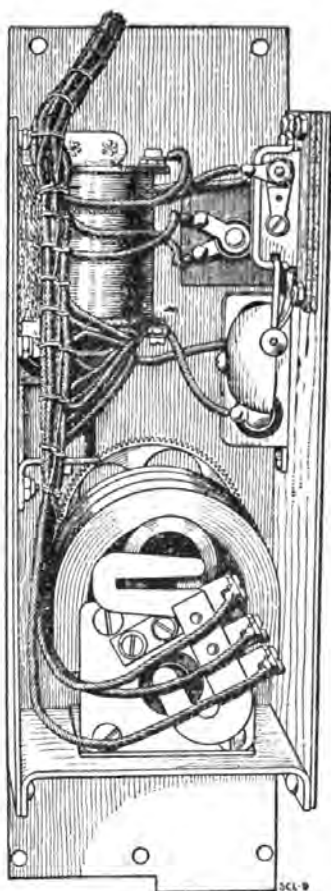

Figure 11.—Operator's telephone set panel—rear view.

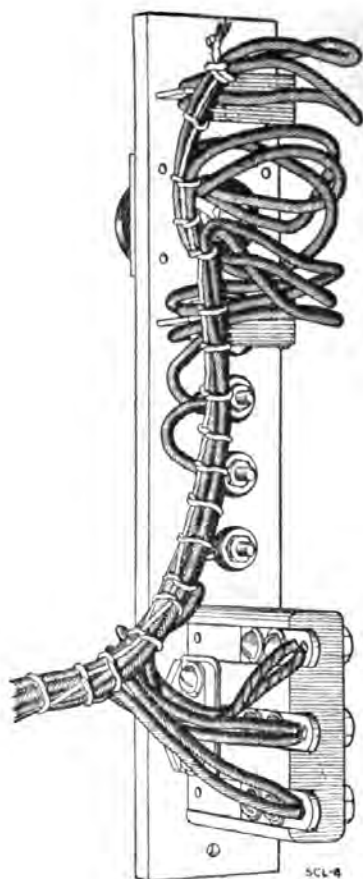

Figure 12.—Jack panel—rear side view.

## SECTION V SUPPLEMENTARY DATA

### 16. CHARACTERISTICS OF CIRCUIT ELEMENTS.

#### a. Transmitter.

Average current through transmitter in use.....	0.1 ampere.
Power output, average (uniformly distributed over 600 to 3,000-cycle range).....	0.003 watt.

#### b. Receiver.

D-c resistance (approximate).....	55 ohms.
Average motional impedance (at 600 to 1,600 cycles).....	256 ohms.

### c. Induction Coil.

Winding	Between terminals	Maximum d-c resistance (ohms)	Inductance (millihenries)
Primary.....	1-2-3	25	120 ± 10 percent.
Balancing.....	2-3	3	5 ± 10 percent.
Mutual inductance.....	3-4	370 ± 5 percent	80 ± 10 percent.
	2-3 to 1-2-3-4		42 ± 10 percent.

### d. Generator.

Gear ratio, crank to armature (approximate) ..... 1 to 5.  
 Output frequency at 1,000 rpm of armature (200 rpm of crank) ..... 16 cycles.  
 Output current at above speed:

Resistance load (ohms):	Current (milliamperes)
200.....	90
1,000.....	50
10,000.....	9.5

Open circuit voltage (approximate) ..... 100 volts.

### e. Drop Winding.

#### (1) Switchboard Unit EE-2-B.

D-c resistance (approximate) ..... 200 ohms.  
 Minimum operating current ..... 0.002 ampere.  
 Impedance at 1,000 cycles (approximate) ..... 3,000 ohms.

#### (2) Switchboard Unit EE-2-C.

D-c resistance (approximate) ..... 500 ohms.  
 Minimum operating current ..... 0.001 ampere.  
 Impedance at 1,000 cycles (approximate) ..... 6,500 ohms.

### f. Repeating Coil.

D-c resistance of line winding (maximum) ..... 65 ohms.  
 D-c resistance of switchboard winding (maximum) ..... 58 ohms.

### g. Battery Drain.

Transmitter battery, average current ..... 0.1 ampere.  
 Night-alarm and lamp battery:  
 Light circuit current ..... 0.6 ampere.  
 Night-alarm circuit current ..... 0.2 ampere.

**17. LIST OF PARTS.** The following list comprises the major component parts of Switchboards BD-71 and BD-72. Those parts preceded by an asterisk (\*) are included in the latest manufactured lots of Switchboards BD-71 and BD-72.

Quantity		Nomenclature	Stock number	Weight each (pounds)
BD-71	BD-72			
1	1	Bell, Edwards & Co. Lungen No. 13 (1 inch)	4Z416	0.1
10	10	Binding Post TM-152	3Z252	.05
15	29	Binding Post TM-175	3Z275	.05
1	1	Capacitor CA-177-A (0.5 $\mu$ f)	3D177A	.2
1	1	Capacitor CA-259 (0.3 $\mu$ f)	3D259	.2
1	1	Coil C-105 (induction)	3C105	.5
2	4	Coil C-161 (repeating)	3C161	2.5
1	1	Cord CC-59 (green) with Plug P1-11, spare	3E59.3	.2
1	1	Crank GC-12	4B456	.2
1	1	Generator GN-38 <i>or</i>	4B838	2.3
1	1	Generator GN-38-A <i>or</i> *	4B838-A	2.3
1	1	Generator GN-38-B*	4B838-B	2.0
1	1	Head and Chest Set HS-19 (see note)	4B1279	2.0
		Consisting of—		
		1 Chest Unit T-26	4B418	1.2
		with—		
		1 Strap ST-24	4Z6924	.25
		1 Strap ST-25	4Z6925	.5
		1 Switch SW-118	3Z8118	
		1 Receiver R-22	4B2522	.3
		1 Headband, item 3, SC-D-1966	4C4153BA	.1
		1 Pad, leather, item 4, SC-D-1966	4C4153BA/1	.05
		1 Cord CC-333	3E333	.2
		1 Cord CC-337	3E337	.1
		1 Plug PL-58	4B2358	.1
1	1	Headset HS-30- ( ) (see note)*	2B830( )	.32
		Consisting of—		
		1 Headband HB-30	2B730	
		2 Receivers R-30- ( )	2B2030( )	
		2 Inserts M-300	2B1300	
		1 Cord CD-620- ( ) 2-conductor	3E1620( )	
1	1	Chest Set TD-1 (see note)*		
		Consisting of—		
		1 Chest Unit T-26	4B418	1.2
		1 Cord CC-333, 6 ft., 3-conductor	3E333	.2
		1 Plug PL-58	4B2358	.1
		1 Strap ST-24	4Z6924	.25
		1 Strap ST-25	4Z6925	.5
		1 Switch SW-118	3Z8118	
1	1	Jack JK-37	4C4277	.2
2	2	Lamp LM-19 (Mazda 14)	6Z6759	.005
1		Leg assembly	4C9971/15	
	1	Leg assembly	4C9972/15	
2	2	Panel Light, Yaxley 330	4C9971/104	.1
2	2	Switch SW-105	3Z8105	.1
6	12	Switchboard Unit EE-2-B or Switchboard Unit EE-2-C with—	4C9912B	1.2
		1 Cord CC-59 (green)	4C9912C	1.2
		1 Plug PL-11	3E59.1	.1
		1 Plug PL-11	4C6211	.1
1	1	Varistor, W. E. Co. No. 3A	4C9971/136	.2
In addition to the above, each switchboard uses but does not include—				
12	12	Battery BA-30, 6 in use, 6 spare	3A30	.2

NOTE.—If Headset HS-30- ( ) and Chest Set TD-1 are not available, Head and Chest Set HS-19 will be used.

