

INSTRUCTION BOOK (OPERATION AND MAINTENANCE)
FOR
RADIO SET SCR-585-B

RESTRICTED

PUBLISHED BY AUTHORITY
OF
THE CHIEF SIGNAL OFFICER

ORDER No. 4267-WF-42

i

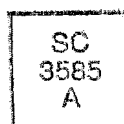

NOTICE

The voltages used in this radio set are not high enough to be injurious. A slight shock, of negligible magnitude, may be obtained by touching the antenna and case at the same time when the set is transmitting.

REPORT OF MAJOR FAILURE

In the event of major failure of any of the component units of this equipment, a report shall be submitted in the form indicated below. Copies of this report shall be forwarded to the Chief, Signal Section, Air Service Command, Patterson Field, Fairfield, Ohio, and to the Director, Signal Corps Aircraft Signal Service, Wright Field, Ohio.

1. Contract or order number.
2. Organization and station.
3. Nomenclature of component unit.
4. Nomenclature of equipment.
5. Date and nature of failure.
6. Type of airplane in which installed.
7. Recommendations.

TABLE OF CONTENTS

SECTION I—DESCRIPTION

Par.		Page
1.	General	1
2.	Frequency Coverage	1
3.	Weights and Dimensions	1
4.	Source of Power	1
5.	Description of Components	1
6.	List of Components of Radio Set SCR-585-B	4

SECTION II—INSTALLATION

7.	Mounting FT-295-B	10
8.	Radio Control Box BC-722-B	10
9.	Cordage CO-220	10
10.	Installation of Batteries BA-37 and BA-38	10
11.	Preparing Radio Receiver and Transmitter BC-721-B for Mounting FT-295-B	13
12.	Control Shaft MC-355 and MC-365-B	13

SECTION III—PREPARATION FOR USE

13.	Glider	15
14.	Adjustment of the Antenna Tuning Capacitor	15
15.	Portable	15

SECTION IV—OPERATION

16.	Normal Operation in Glider	16
17.	Operation as a Portable Radio Telephone	16
18.	Operation in the Rain	17
19.	Poor Reception	17
20.	Locating Trouble	17
21.	Usable Communication Distance	17
22.	Operation Common to Glider and Portable Radio Telephone	18

SECTION V—MAINTENANCE

23.	Locating Trouble When Set Does Not Operate	19
24.	Replacement of the Batteries	19
25.	Replacement of the Tubes	19
26.	Replacement of the Antenna Coil	19
27.	Replacement of the R-F Tank Coil	19
28.	Replacement of the Microphone	19
29.	Replacement of the Earphone	19
30.	Removal and Replacement of the Crystals	19
31.	Poor Reception and Transmission	19
32.	Alignment Procedure Using Test Equipment IE-17-B	19
33.	Procedure if Badly out of Alignment	28
34.	Change of Frequency	29
35.	Test Procedure for Radio Control Box BC-722-B and Cordage CO-220	29
36.	Test Procedure for Mounting FT-295-B	30
37.	Test Procedure for Batteries BA-37 and BA-38	30

APPENDIX

38	Table of Replaceable Parts	39
----	--------------------------------------	----

ILLUSTRATIONS

Figure	Page
1 Radio Set SCR-585-B, Components.....	x
2 Radio Receiver and Transmitter BC-721-B.....	2
3 Radio Set SCR-585-B, Using End-Fastening Control Shaft MC-365-B.....	3
4 Radio Set SCR-585-B, Using Bottom-Fastening Control Shaft MC-355.....	5
5 Radio Receiver and Transmitter BC-721-B, Showing Battery Compartment.....	6
6 Radio Receiver and Transmitter BC-721-B, Disassembled.....	7
7 Cordage CO-220 and Plugs PL-203 and PL-237, Assembly Detail.....	8
8 Mounting FT-295-B and Radio Control Box BC-722-B, (Bottom View).....	9
9 Control Shaft MC-365-B, Installation, Shown in End Fastened Position.....	11
10 Control Shaft MC-355, Installation, Shown in Bottom Fastened Position.....	11
11 Control Shaft MC-355 and MC-365-B, Installation and Adjustment Detail.....	12
12 Test Equipment IE-17-B, Set-Up for Receiver Alignment.....	20
13 Test Unit I-135-B.....	21
14 Test Unit I-135-B Showing Battery Compartment.....	23
15 Radio Receiver and Transmitter BC-721-B, Chassis (Front View).....	24
16 Radio Receiver and Transmitter BC-721-B, Chassis (Bottom View).....	25
17 Mounting FT-295-B, Schematic Diagram.....	31
18 Radio Control Box BC-722-B, Schematic Diagram.....	32
19 Radio Receiver and Transmitter BC-721-B on Mounting FT-295-B, Outline Dimensional Detail	33
20 Radio Control Box BC-722-B, Outline Dimensional Detail.....	34
21 Typical Installation of Radio Set SCR-585-B, in Glider.....	35
22 Radio Receiver and Transmitter BC-721-B, Tube Socket and Terminal Voltage Diagram.....	36
23 Radio Receiver and Transmitter BC-721-B, Bottom Cover Wiring Diagram.....	37
24 Radio Receiver and Transmitter BC-721-B, Resistor-Capacitor Cups, Schematic Diagram.....	38
25 Functional Diagram of Receiver of BC-721-B.....	52
26 Functional Diagram of Transmitter of BC-721-B.....	53
27 Radio Receiver and Transmitter BC-721-B, Schematic Diagram.....	54

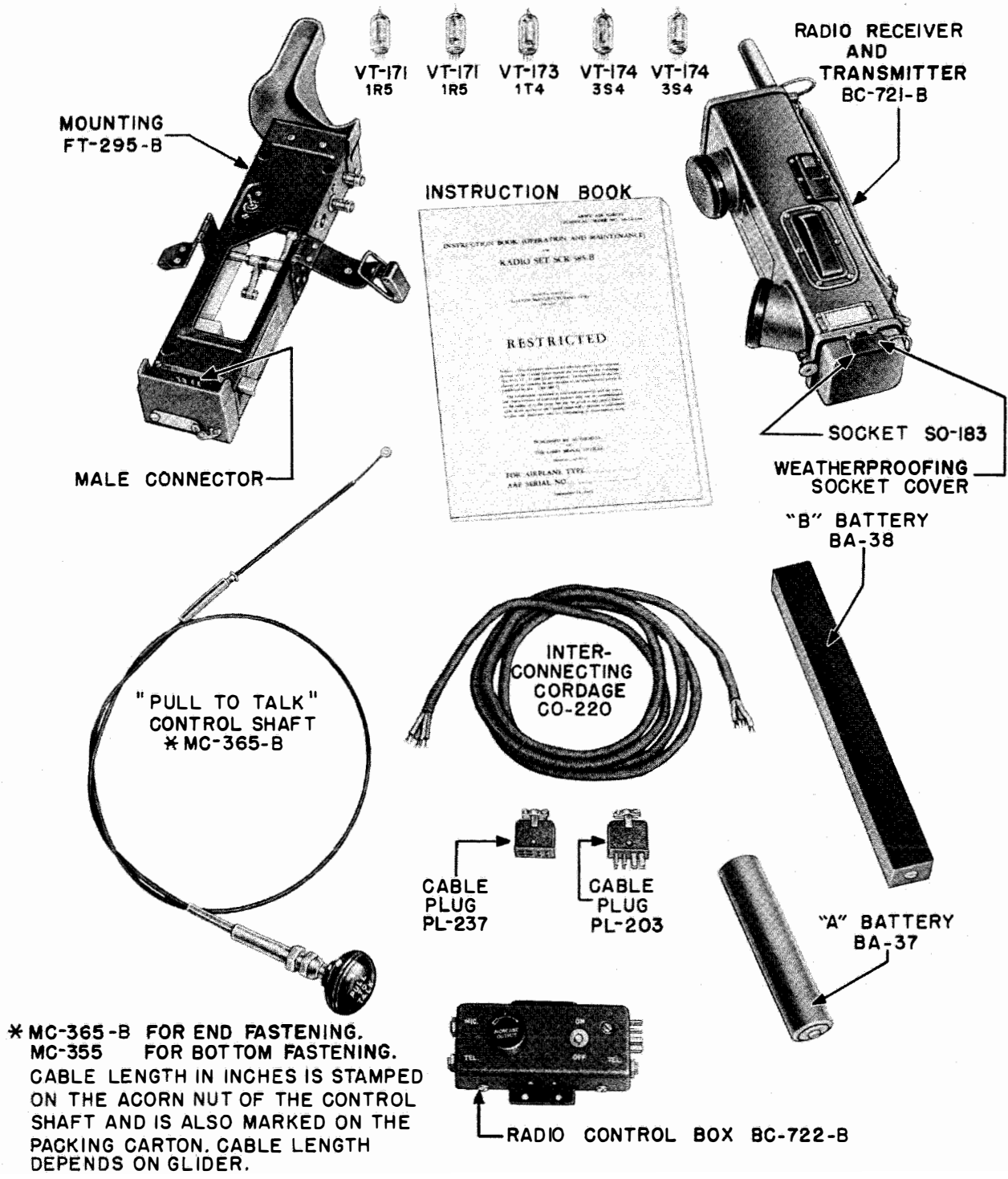

FIG. 1. RADIO SET SCR-585-B, COMPONENTS

SECTION I DESCRIPTION

1. GENERAL.

a. Radio Set SCR-585-B is a dual purpose radio receiver and transmitter, designed for two-way conversation over distances up to one mile. Descriptively, it is a portable radio telephone, receiving and transmitting on the same frequency.

b. For use in a glider it is placed on a Mounting FT-295-B, installation to be made as specified for the particular type of glider used. Radio Receiver and Transmitter BC-721-B when installed on Mounting FT-295-B is remotely controlled by "PULL-TO-TALK" Control Shaft MC-355 or MC-365-B, and Radio Control Box BC-722-B.

c. For operation in the glider, headphones and a throat microphone are used. Both pilot and co-pilot have headphones available, but provision is made for only one microphone. Radio Control Box BC-722-B contains jacks for two sets of headphones, a jack for a microphone, an "ON-OFF" switch, a volume control, and a microphone matching transformer.

d. By unbuckling the strap and buckle assembly, shown in Fig. 3, and pushing the connector release lever, Radio Receiver and Transmitter BC-721-B is released and becomes a "press-to-talk" self-contained portable radio telephone with attached earphone and microphone resembling an ordinary hand telephone set. Radio Receiver and Transmitter BC-721-B when operated in this manner is automatically turned on when the self-contained telescopic antenna is fully extended. No volume control is used with the radio receiver and transmitter when it is used as a portable radio telephone. See Fig. 2.

2. FREQUENCY COVERAGE.—The unit is crystal controlled on both reception and transmission, and will operate over the frequency range of 3500 to 6000 kilocycles. However, each unit is adjusted to operate at only one frequency at a time in this band. Reception and transmission are on the same frequency. The set can be made to operate at any frequency in the band by proper choice of crystals and coils. For correct performance, each set must have coils adjusted to the crystals used. The coils and crystal changes and their adjustments cannot be made by the operator, but are set by the manufacturer or by maintenance men at authorized repair depots.

The bottom of the case of Radio Receiver and Transmitter BC-721-B has a hinged cover which permits access to the batteries and the radio chassis. See Fig. 5.

3. WEIGHTS AND DIMENSIONS.—Total weight of Radio Set SCR-585-B is approximately 11½ lbs., depending on cable length required in glider. Total weight of Radio Receiver and Transmitter BC-721-B is 6 lbs. Overall dimension of Radio Receiver and Transmitter BC-721-B on Mounting FT-295-B is approximately 6" high, 5½" wide, 17¼" long. See Fig. 19.

4. SOURCE OF POWER.—Radio Receiver and Transmitter BC-721-B is battery powered. Space for both "A" and "B" batteries is provided in the housing.

The filament or "A" Battery BA-37, rated at 1.5 volts, is cylindrical in shape and fits into the round compartment in the housing.

The "B" Battery BA-38, rated at 103½ volts, is oblong in shape and fits into the oblong compartment in the housing.

	<i>Drain Receiving</i>	<i>Drain Transmitting</i>
"A" Battery BA-37 1.5 volts.	0.35 amps.	0.30 amps.
"B" Battery BA-38 103.5 volts.	16 milliamperes (max.)	35 milliamperes (max.)

5. DESCRIPTION OF COMPONENTS.

a. *Housing for Radio Receiver and Transmitter BC-721-B.*—The housing which encloses Radio Receiver and Transmitter BC-721-B is an aluminum casting. Its interior is divided into three compartments, one for the radio chassis, one for "A" Battery BA-37, and one for "B" Battery BA-38. Two projections from the housing contain the earphone and microphone units. These projections are so spaced and of such length that when the unit is held with the earphone against the ear of the operator, the microphone or mouthpiece is in the proper position for talking.

A "press-to-talk" switch is mounted on the side of the case, and operates the change-over switch on the radio chassis which converts the set from a receiver to a transmitter. This switch is so located that when the set is held in the left hand, the switch may be operated easily with the fingertips. See Fig. 2.

The bottom cover hinges to the housing and is provided with a slot into which a latching bolt fits. It is through this end of the housing that the chassis and batteries are inserted or removed. A contact terminal board inside the bottom cover provides the

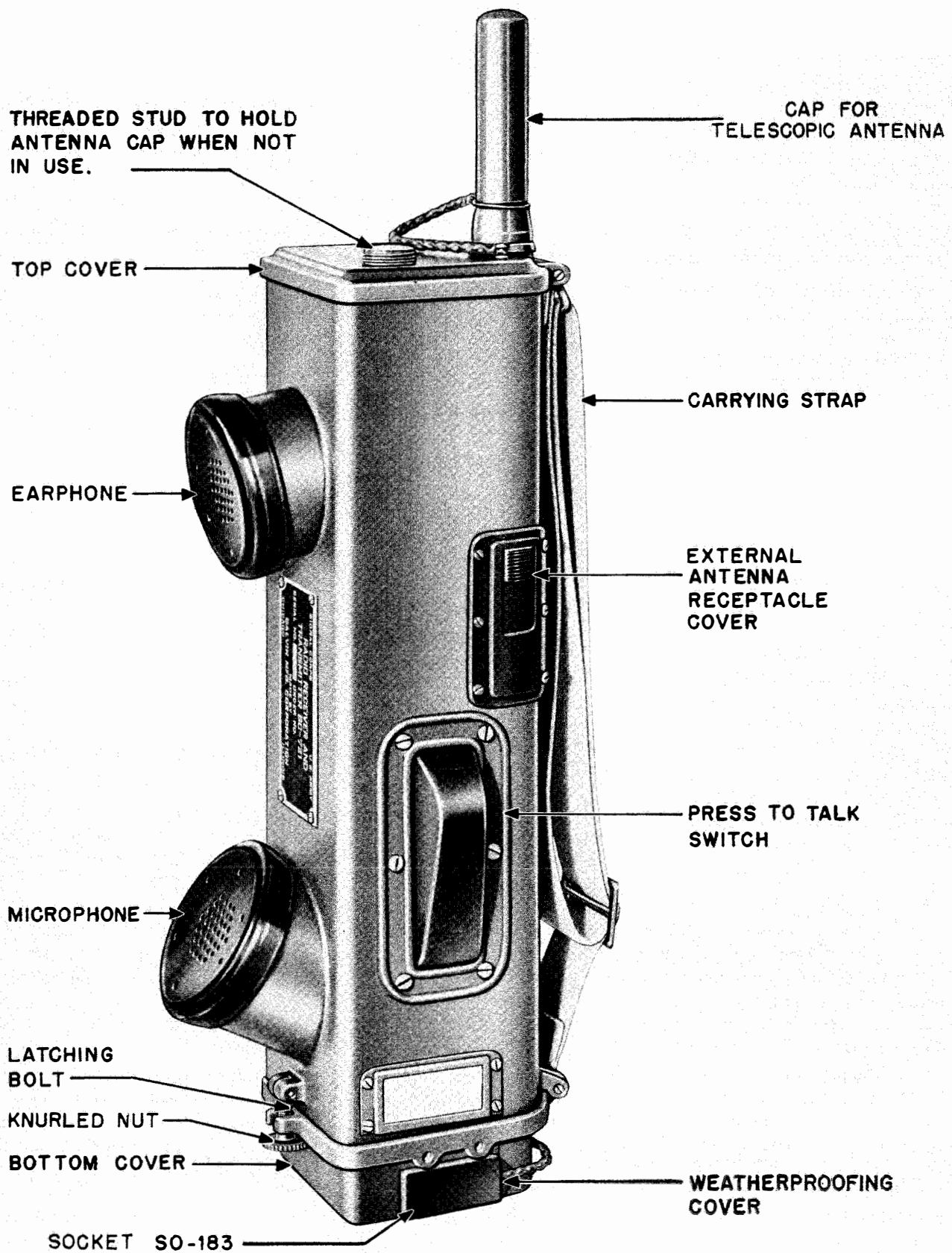

FIG. 2. RADIO RECEIVER AND TRANSMITTER BC-721-B

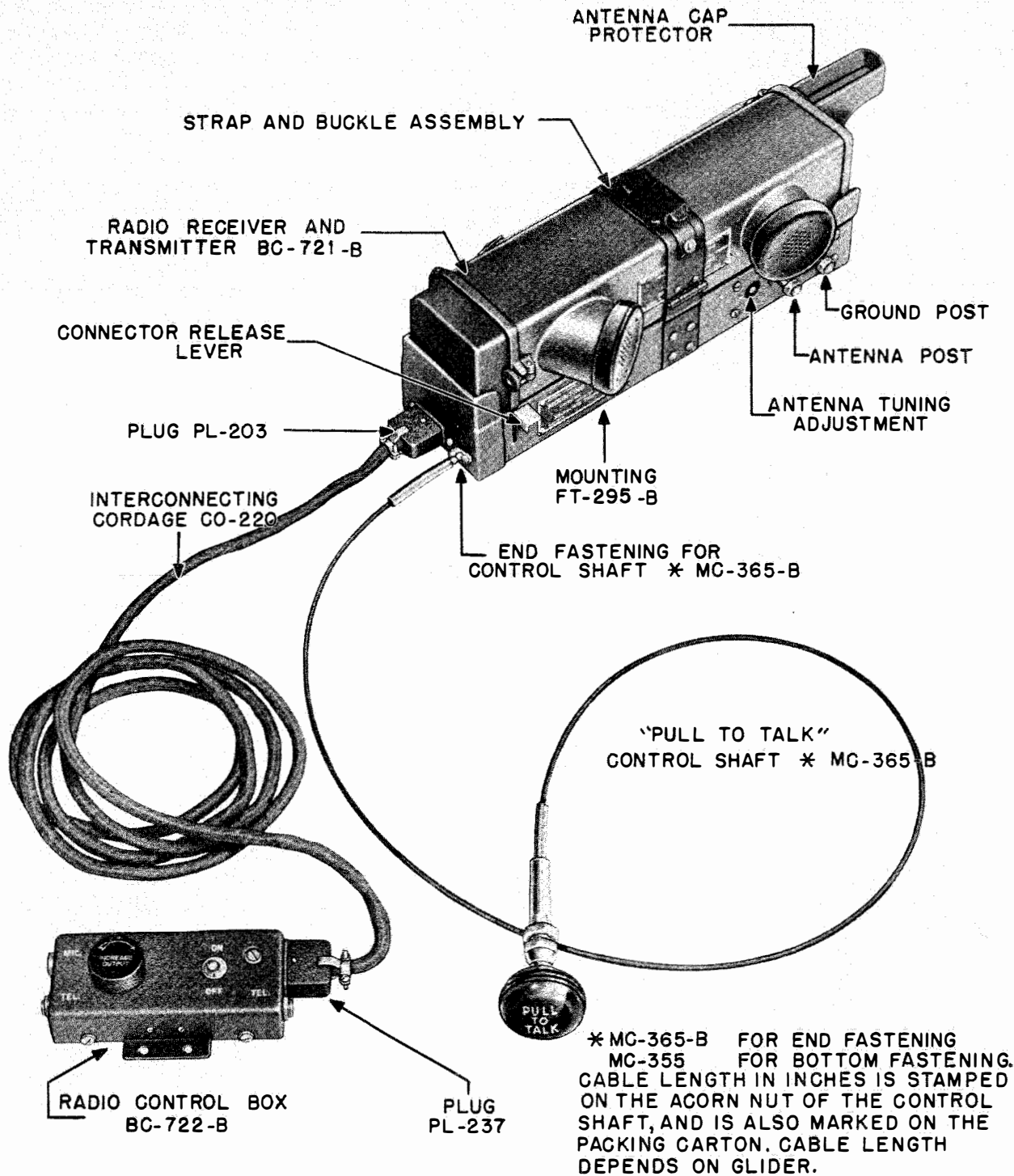

FIG. 3. RADIO SET SCR-585-B, USING END-FASTENING CONTROL SHAFT MC-365-B

connections between the batteries and the radio chassis, as well as to the Socket SO-183 which makes the necessary electrical connection with Mounting FT-295-B. See Fig. 5.

A small card holder below the "press-to-talk" switch contains a plastic card on which the frequency and battery dates are marked. This card is protected from wear by a transparent cover. To remove the card from its container the bottom cover must be opened.

The top cover of the set contains an opening for the antenna rod. This cover is held in place by a mounting screw which holds the chassis securely in the housing. Spring battery contacts and a spacer for "A" Battery BA-37, fastened to the top cover, make electrical connections to the batteries. See Fig. 6.

An antenna cap, attached to the top cover on the outside by a chain, protects the telescopic rod antenna against weather conditions when the set is not in use, and when the unit is carried, or mounted on Mounting FT-295-B.

b. Cordage CO-220.—This is a seven-conductor cable used to connect Radio Control Box BC-722-B to Mounting FT-295-B. Due to different types of glider installations, the cordage is furnished in running lengths and should be cut to the length desired for each type of installation. Fig. 7 shows the color code connections to the plugs. Care must be used when assembling Plugs PL-203 and PL-237 to the cordage to prevent short circuiting the conductors, and short lengths of sleeving or spaghetti should be placed over the soldered connections.

c. Mounting FT-295-B.—This mounting contains an antenna tuning capacitor to tune the antenna circuit of Radio Receiver and Transmitter BC-721-B to the external antenna used in the glider.

A headset matching transformer is mounted inside of Mounting FT-295-B. This transformer matches the output circuit of Radio Receiver and Transmitter BC-721-B to one or two pair of either high or low impedance Signal Corps headsets. Terminals for making the proper impedance connections are provided on the transformer which is normally supplied with connection made for high impedance Headsets (HS-23 Type).

An eight-terminal male connector mounted on the base makes contact with Socket SO-183 when Radio Receiver and Transmitter BC-721-B is clamped in Mounting FT-295-B. See Fig. 8.

The external antenna connection to the radio set is made through an antenna plug assembly installed in Mounting FT-295-B. This plug is self-centering on the mounting to assure perfect alignment with the antenna receptacle in Radio Receiver and Transmitter BC-721-B. When the antenna plug passes into the external antenna receptacle, it actuates a switch in Radio Receiver and Transmitter BC-721-B. This switch transfers the radio antenna connection from the internal telescopic rod antenna to the external antenna.

A strap and buckle assembly attached to the mounting holds Radio Receiver and Transmitter BC-721-B securely in position.

d. "PULL-TO-TALK" Control Shafts MC-355 or MC-365-B.—This assembly consists of a flexible housing and Bowdin wire, together with the necessary mounting fittings and control knob. It is fastened at either the end or bottom of Mounting FT-295-B and actuates the Send-Receive switch in Radio Receiver and Transmitter BC-721-B. See Figs. 3 and 4.

e. Radio Control Box BC-722-B.—This box contains the ON-OFF power switch, INCREASE OUTPUT volume control (receiver volume), jacks for the headphones and microphone, a microphone transformer, and male Connector SO-217. See Figs. 4 and 8.

6. LIST OF COMPONENTS OF RADIO SET SCR-585-B.

Quantity	Article	Unit Weight
1	("A") Battery BA-37, 1.5 volts65 lb.
1	("B") Battery BA-38, 103½ volts	1.10 lb.
1	Control Shaft MC-355 or MC-365-B	approx. .50 lb.
1	Cordage, CO-220	per ft. .06 lb.
1	Mounting, FT-295-B	3.30 lbs.
1	Plug, PL-20305 lb.
1	Plug, PL-23705 lb.
1	Preliminary Instructions for Radio Set SCR-585-B10 lb.
1	Radio Control Box BC-722-B87 lb.
1	Radio Receiver and Transmitter BC- 721-B (With Coil Sets and Crystals but less batteries)	4.25 lbs.
4	Tubes VT-171 (2 in use, 2 spare)10 lb.
2	Tubes VT-173 (1 in use, 1 spare)10 lb.
4	Tubes VT-174 (2 in use, 2 spare)10 lb.

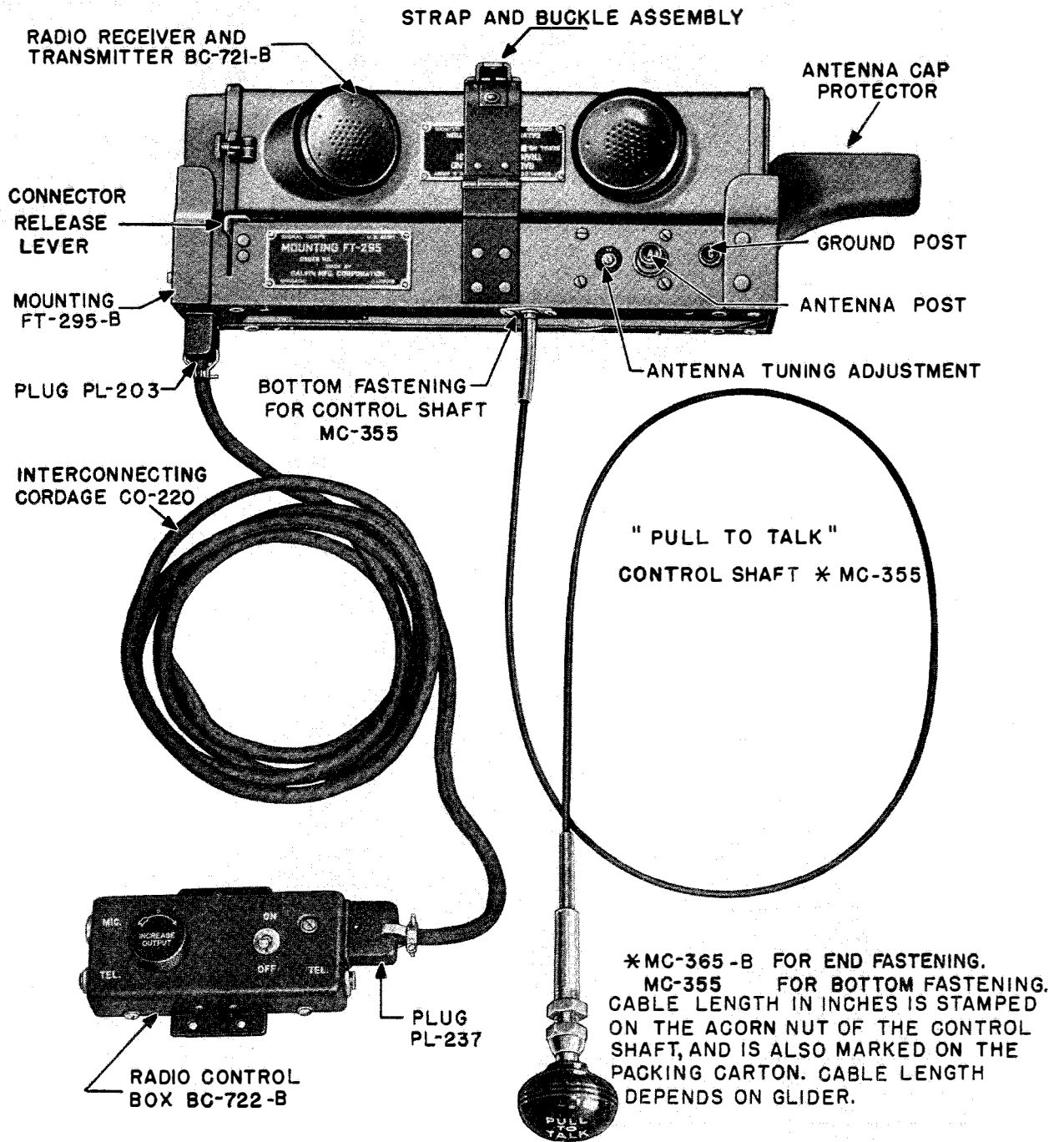

FIG. 4. RADIO SET SCR-585-B, USING BOTTOM-FASTENING CONTROL SHAFT MC-355]

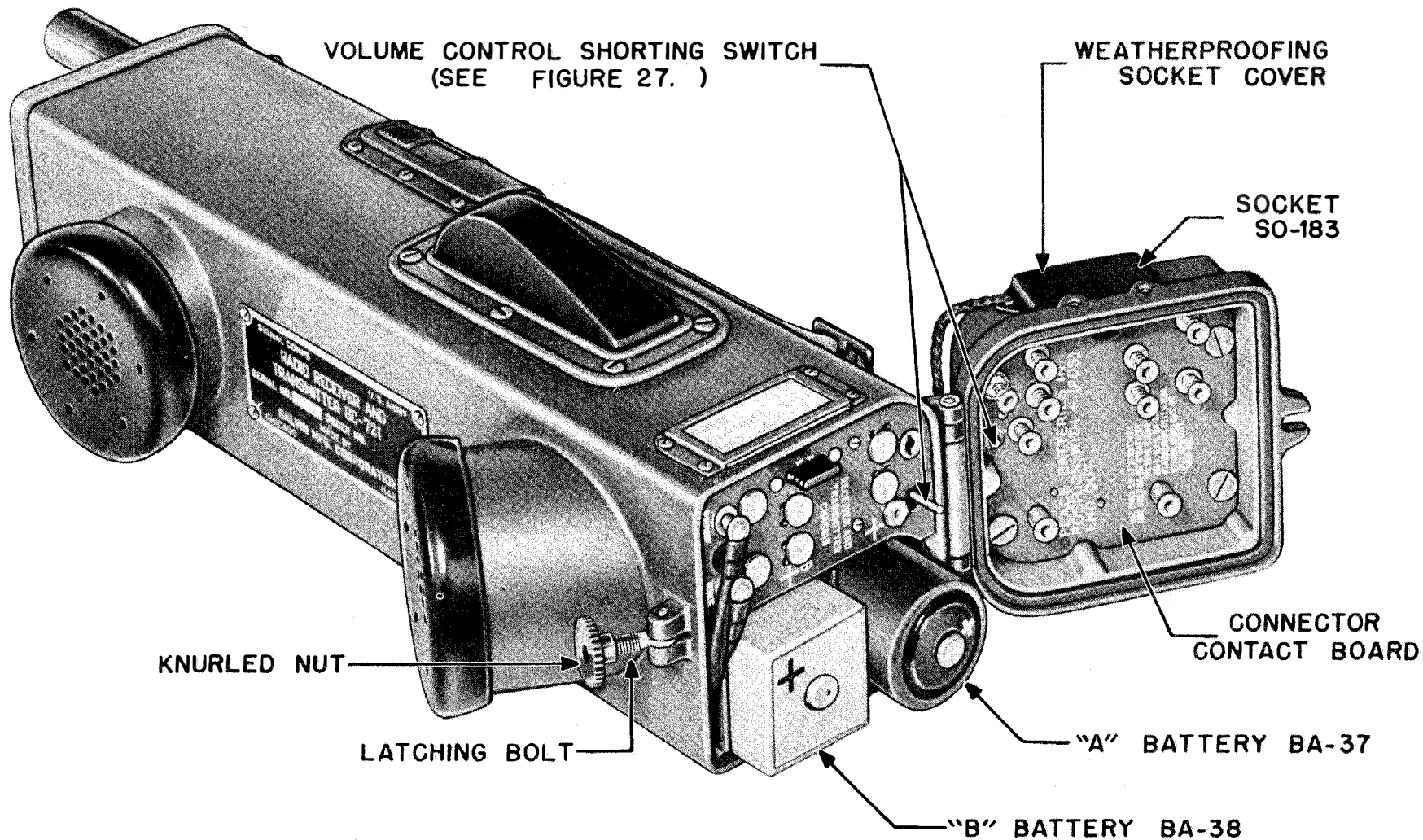

FIG. 5. RADIO RECEIVER AND TRANSMITTER BC-721-B, SHOWING BATTERY COMPARTMENT

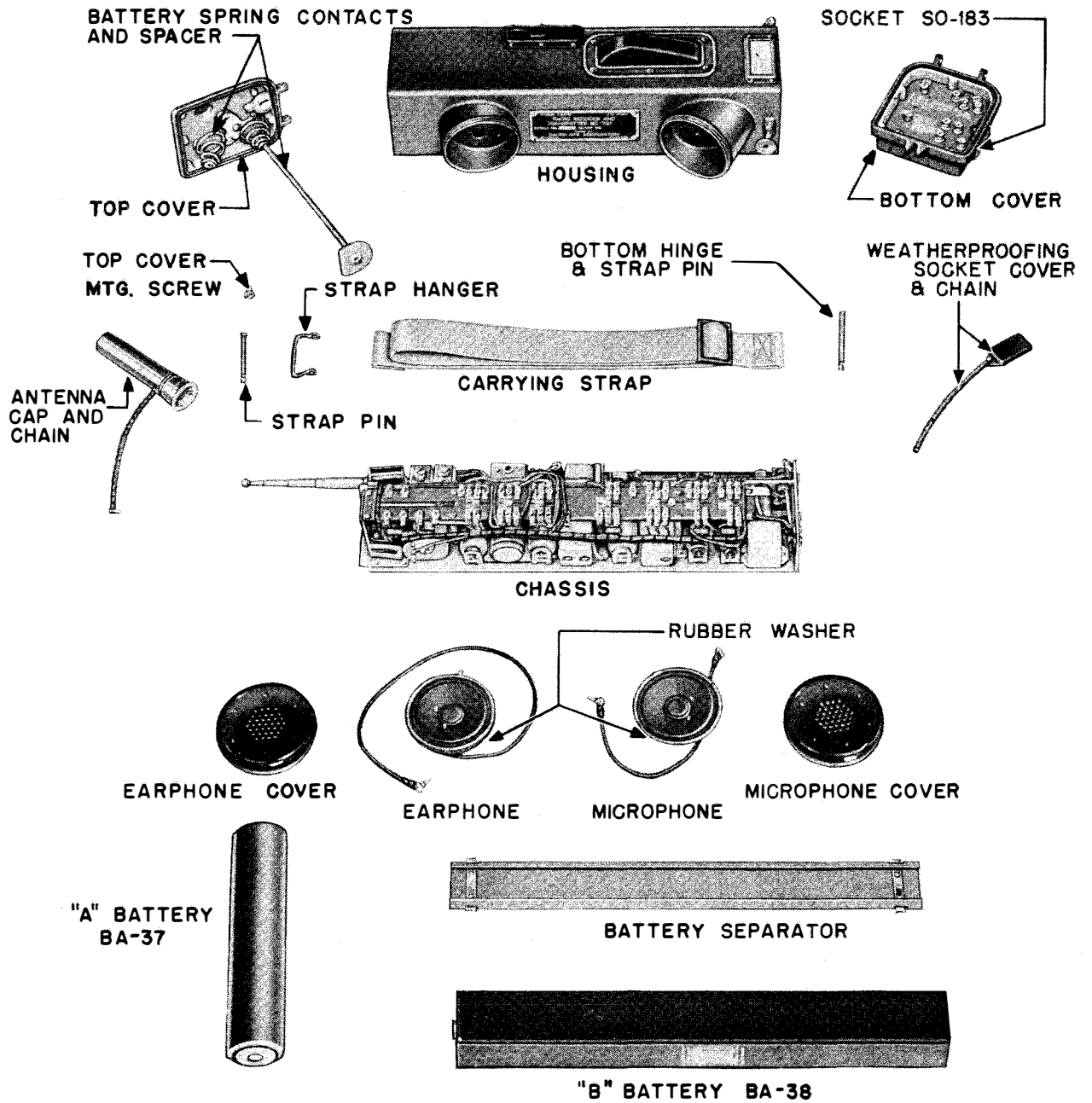
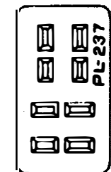
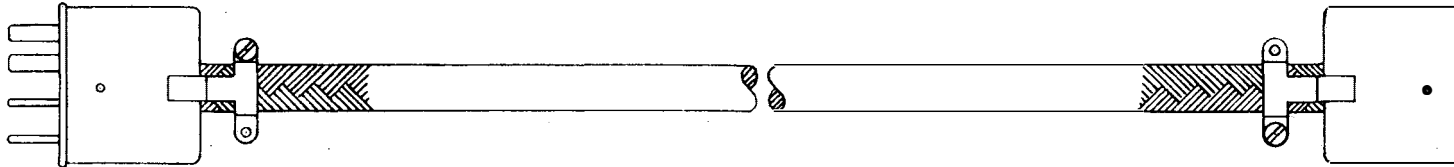
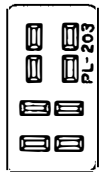
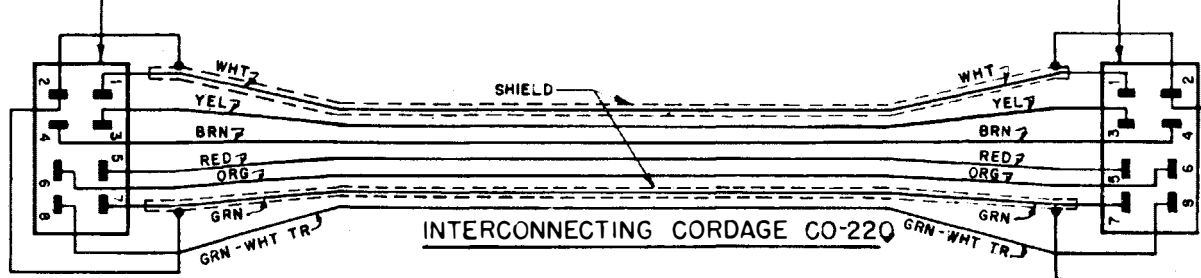

FIG. 6. RADIO RECEIVER AND TRANSMITTER BC-721-B, DISASSEMBLED



PLUG PL-203 (MALE)
(REAR VIEW)

PLUG PL-237 (FEMALE)
(REAR VIEW)



LEADS TO BE SECURELY AND NEATLY
SOLDERED TO TERMINALS. LEADS TO
BE CAREFULLY DRESSED TO AVOID
SHORTING IN ASSEMBLY.

WEIGHT OF CABLE COMPLETE -
.06 LB. PER FOOT PLUS .10 LB.
FOR PLUG AND SOCKET.

FIG. 7. CORDAGE CO-220 AND PLUGS PL-203 AND PL-237, ASSEMBLY DETAIL

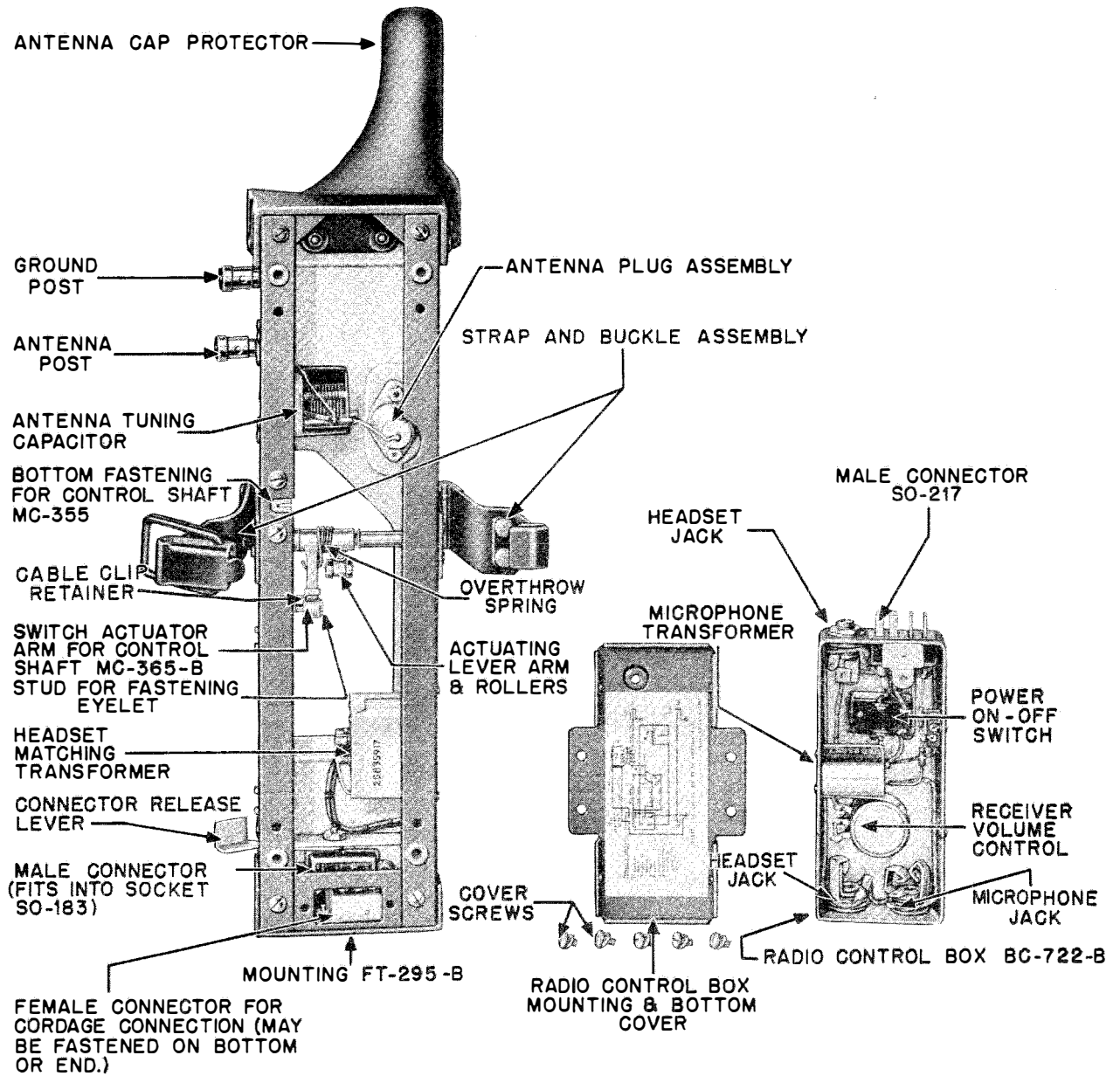

FIG. 8. MOUNTING FT-295-B AND RADIO CONTROL BOX BC-722-B, (BOTTOM VIEW)

SECTION II INSTALLATION

7. MOUNTING FT-295-B.—Mounting FT-295-B should normally be located in a position in the glider so that it is accessible for quick removal of Radio Receiver and Transmitter BC-721-B. This condition does not apply to small two place training gliders. There are several locations where the mounting may be placed, and there are two methods of installing Mounting FT-295-B as shown in Figs. 9 and 10. The antenna lead-in should be *kept away* from all cables, the metal portion of the fuselage, and the personnel.

a. The first method, shown in Fig. 9, is used when it is possible to get underneath the structure supporting the mounting to insert the fastening screws. Elastic stop nuts are riveted to the fastening flange on Mounting FT-295-B and prevent loosening of the screws due to vibration.

b. When it is necessary to install Mounting FT-295-B against a solid object, or where there is very little space behind the mounting support, the second method, shown in Fig. 10, should be used. There is a large opening directly above the screw holes in the mounting, through which a screw driver may be inserted.

c. Mounting FT-295-B is shipped from the factory with the female connector mounted either in the end or bottom of the mounting, as ordered. See Fig. 3 and 4. When this connector is fastened in the bottom of the mounting, the opening provided for end fastening is covered with a plate held in place by two screws. To change to end mounting, remove the plate and the screws holding the connector on the bottom of the base. Move the connector into position on the end of the base, using the two original mounting screws.

An easier method is to first remove the rear guide flange on the end of Mounting FT-295-B. The two screws on top of the chassis and the two screws on the bottom must first be removed. The end guide flange can then be worked loose from the chassis and transfer of the connector be readily made.

8. RADIO CONTROL BOX BC-722-B.—Radio Control Box BC-722-B should be mounted in a location that is accessible to the pilot or co-pilot, and should be fastened down securely. See Fig. 21.

a. Microphone and Headset Extension Cordages.—

The headset and microphone extension cords must be cut to length for each particular type of glider

and must be assembled with care to prevent short-circuiting of the conductors.

The headset extension cords consist of Plug PL-55, Jack JK-26, and Cordage CO-119. The microphone extension cord consists of Plug PL-68, Jack JK-48 and Cordage CO-219. Jack JK-48 comprises two tenite sections which must be cemented together with a solution of Normal Butyl Acetate, a solvent. Refer to Signal Corps Drawing SC-B-3242 for more detailed information.

After assembly of the extension cords, they shall be plugged into their respective TEL. and MIC. jacks in Radio Control Box BC-722-B and then fastened securely to the fuselage between the radio control box and the pilot positions. The extension cords must be of sufficient length to permit each pilot normal freedom of movement.

9. CORDAGE CO-220. — A seven-conductor cable is used to connect Radio Control Box BC-722-B to Mounting FT-295-B. Due to different types of installations, the cordage is furnished in running lengths and must be cut to the length desired for each individual installation. Fig. 7 shows the color code connections to Plugs PL-203 and PL-237, male and female respectively. Care must be used, when assembling plugs to cordage, and short lengths of sleeving or spaghetti should be placed over the soldered connections to prevent short circuiting the conductors.

10. INSTALLATION OF BATTERIES BA-37 AND BA-38.—The set is furnished by the manufacturer with everything contained in the housing except batteries. However, the necessary batteries to put the set into operation must be in place. To install the batteries, open the bottom cover by turning the knurled nut on the latching bolt counter-clockwise, until the nut begins to turn with difficulty. Then press the cover against the case and push the bolt away from the housing. Release the cover and it will open. See Fig. 5.

a. The filament or "A" Battery BA-37, which is cylindrical in form, fits into the round compartment in the housing. The battery should be inserted into the housing with the positive contact facing out. The positive end of the battery is marked with a large positive (+) sign. Another means of identifying the positive end of the battery is the small raised metal button. If the light is insufficient to read the marking on the battery or that on the battery contact board in the bottom cover of the housing,

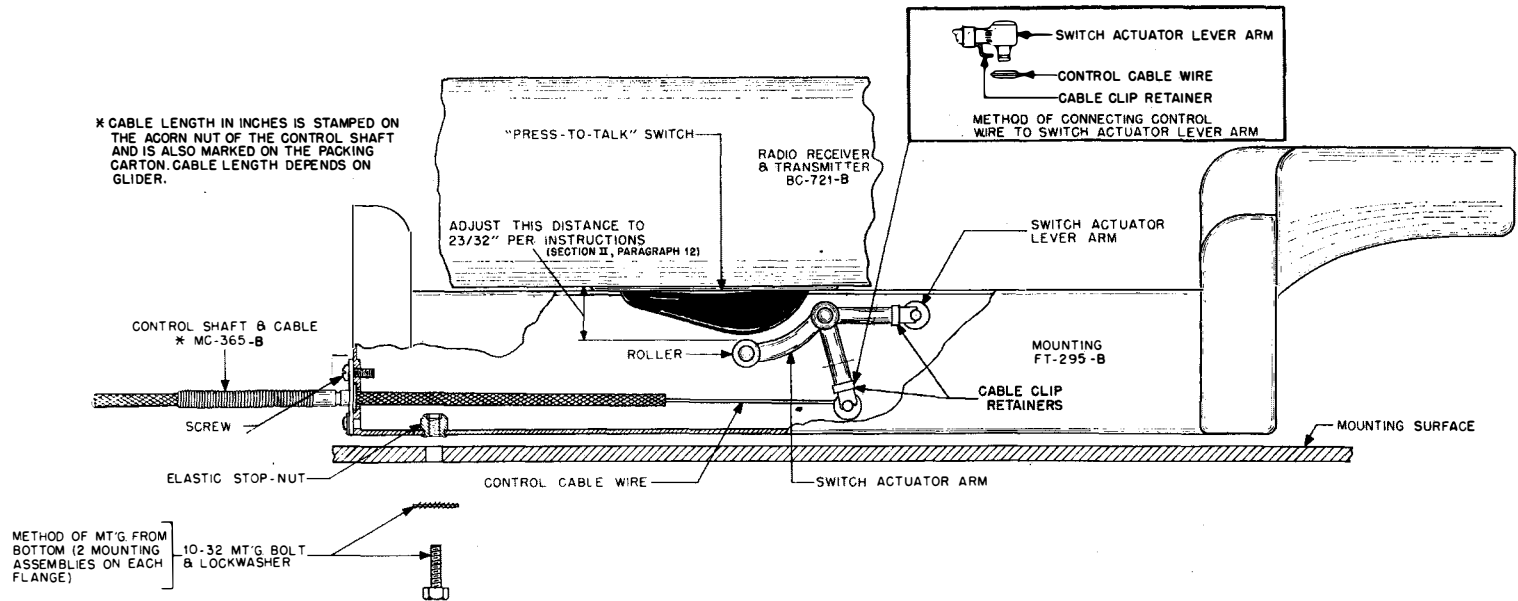

FIG. 9. CONTROL SHAFT MC-365-B, INSTALLATION, SHOWN IN END FASTENED POSITION

11

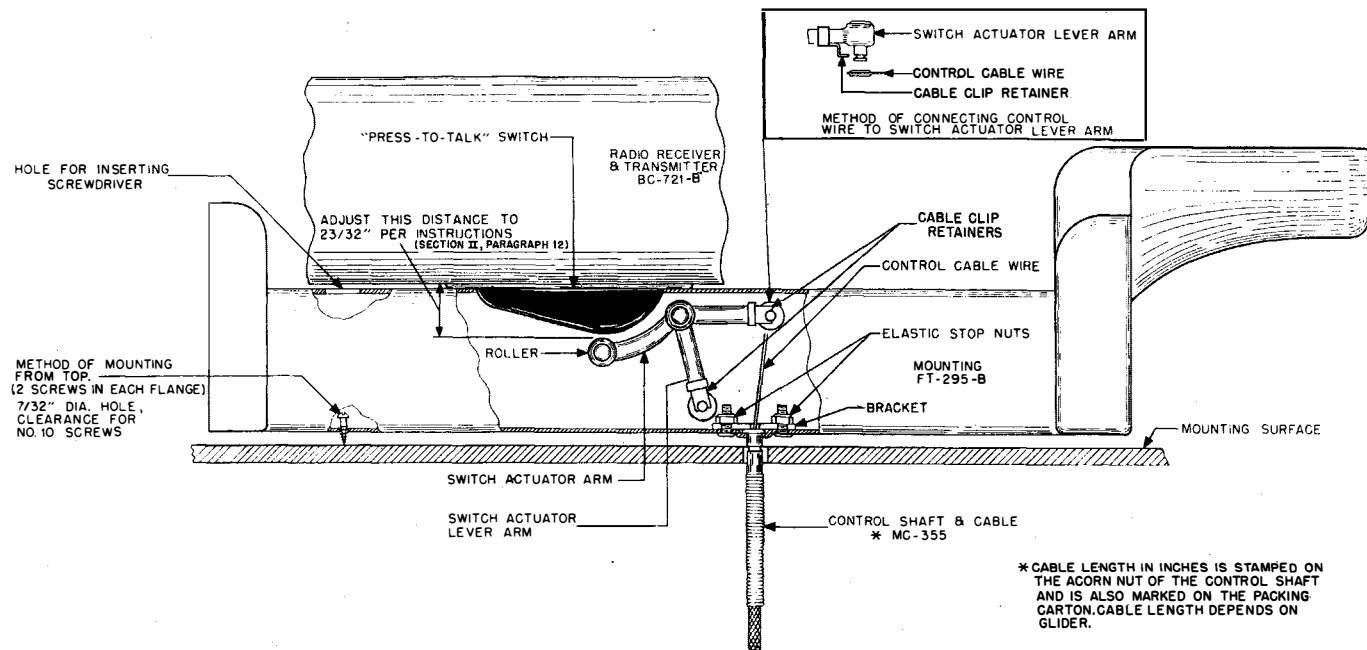

FIG. 10. CONTROL SHAFT MC-355, INSTALLATION, SHOWN IN BOTTOM FASTENED POSITION

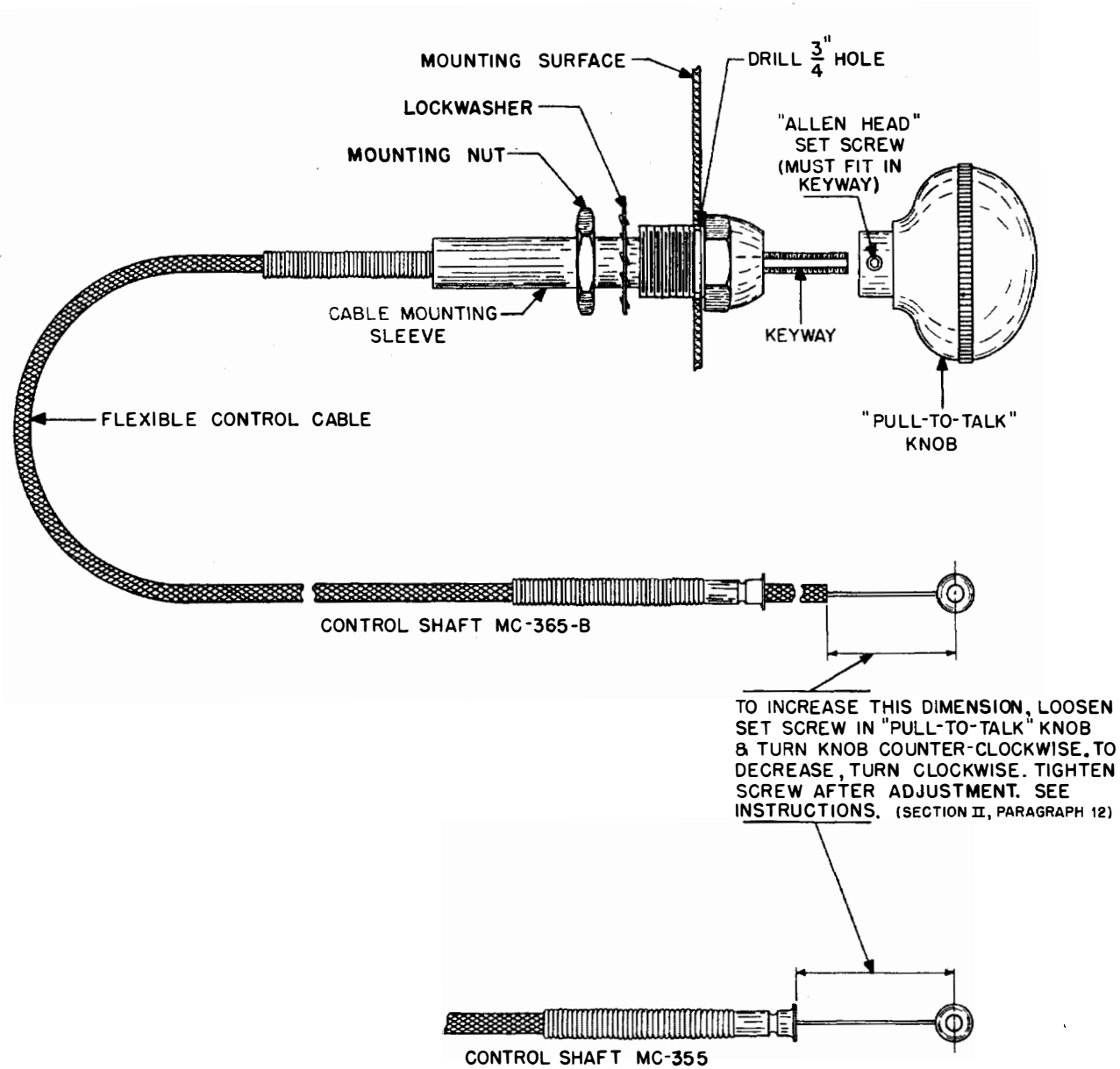

FIG. 11. CONTROL SHAFT MC-355 AND MC-365-B, INSTALLATION AND ADJUSTMENT DETAIL

as would occur when changing batteries in the dark, this button can be used to identify the positive end of the battery.

b. "B" Battery BA-38, is oblong in shape and fits into the oblong compartment in the housing. It must be placed into the compartment with the positive end out. This end of the battery is marked with a large positive (+) sign. This battery also has a small raised metal button, which may be used to identify the positive terminal.

NOTE.—*Before closing the cover, mark the date of the battery change on the card in the pocket below the "press-to-talk" switch.* The card is removed by sliding it out of the bottom of the pocket. The transparent cover piece will also come out with the card. Erase the battery date that is marked on the card and put on a new date. When re-inserting the card into the pocket, remember to place the transparent protecting piece over the card.

c. After the batteries are inserted, the cover is closed by pressing it against the housing with one hand, while the other hand moves the latching bolt into the slot in the cover and tightens the knurled nut by turning it clockwise. The cover should then be pressed against a solid object and the knurled nut tightened until it turns with great difficulty. This is necessary so that Radio Receiver and Transmitter BC-721-B will properly fit into Mounting FT-295-B. The spring contacts in the hinged cover will then make positive contact.

11. PREPARING RADIO RECEIVER AND TRANSMITTER BC-721-B FOR MOUNTING FT-295-B.

a. Slide the external antenna receptacle cover down, exposing the antenna receptacle. See Fig. 2.

b. Be sure that the telescopic antenna is pushed down into position and the antenna cap is in place, as shown in Fig. 2.

c. Remove the waterproof protective cover from the hinged base Socket SO-183. See Fig. 2.

d. Place Radio Receiver and Transmitter BC-721-B on Mounting FT-295-B, as shown in Fig. 3, and fasten the strap and buckle assembly. Care should be used when placing the unit on Mounting FT-295-B to keep the antenna cap chain clear of the antenna cap protector casting. This may be done by keeping the chain on the carrying strap side of the antenna guard.

Installation of Radio Receiver and Transmitter BC-721-B on Mounting FT-295-B will be made easier if the eight contact Socket SO-183 in Radio Receiver and Transmitter BC-721-B is guided into

the connector Mounting FT-295-B before connection is made with the antenna plug.

e. Connect the glider antenna to the antenna binding post marked "A" on Mounting FT-295-B. See Fig. 3.

f. Connect a wire from the ground binding post marked "G" on Mounting FT-295-B to the metal structure part of the glider. This ground wire should be as short as possible and the paint and scale must be completely removed from the grounding point on the metal structure before the clamp is applied.

12. CONTROL SHAFT MC-355 AND MC-365-B.—There are two types of control shafts designed to provide remote control of the "transmit" and "receive" functions of Radio Receiver and Transmitter BC-721-B through operation of a "PULL-TO-TALK" knob.

Control Shaft MC-365-B is for end fastening to Mounting FT-295-B. Control Shaft MC-355 is for bottom fastening to Mounting FT-295-B. See Figs. 3 and 4.

These two types are furnished in various lengths depending on the type of glider. To identify them, the proper nomenclature as well as the length in inches is stamped on the acorn nut of the control shaft. The packing carton is similarly marked.

a. Mount the "pull-to-talk" control shaft in the position specified by the plans and installation specifications of the particular glider. Installation of the control in any other position will require a "pull-to-talk" control shaft of different length. The control should be mounted in such a position that the engraving "Pull-to-Talk" can be easily read by the pilot.

b. Run the flexible control shaft to the Mounting FT-295-B avoiding any bends of less than 6-inch radius. A radius smaller than 6 inches causes too much friction on the inner Bowdin wire. On long runs where no other means of anchoring the cable are used, the outside casing should be fastened securely to the glider structure but care must be taken so as not to crimp cable.

c. Refer to Fig. 9 if the end fastening method is used, or to Fig. 10 if the bottom fastening method is used. Place the eyelet of the Bowdin wire over the stud on the actuating arm of the lever and slide the retaining cable clip in position. See Fig. 8. Crimp this clip over the stud with a pair of pliers.

d. The adjustment for the control shaft cable is then made by loosening the set screw on the "PULL-TO-TALK" knob with a $\frac{1}{16}$ " Allen set screw wrench and turning the knob clockwise to shorten the distance

Par. 12

between the arm and top of Mounting FT-295-B. The distance should be $2\frac{3}{32}$ inches from the top. To increase the distance, turn counterclockwise. See Figs. 9, 10 and 11.

The adjustment for the control shaft can also be made by fastening a Radio Receiver and Transmitter BC-721-B on Mounting FT-295-B and then adjusting the "PULL-TO-TALK" knob until there is $\frac{1}{16}$ " of slack in the control before the lever arm en-

gages the rubber covered change-over switch. The point at which the lever arm engages the change-over switch can be felt at the "PULL-TO-TALK" control knob if it is slowly pulled outward.

After the adjustment of the control shaft has been made, the Allen set screw should be tightened down only on the keyway portion of the control shaft—never on the threads.

SECTION III PREPARATION FOR USE

13. GLIDER.—After making the installation as described in Section II, plug the throat microphone (T-30 type) into the microphone extension cord jack and the headsets (HS-23 type) into the headphone extension cord jacks which are connected to the proper MIC. and TEL. jacks in Radio Control Box BC-722-B.

14. ADJUSTMENT OF THE ANTENNA TUNING CAPACITOR.—Place an 0-100 r-f milliamperemeter (See Note) in series with the antenna external lead at the “A” binding post on Mounting FT-295-B, keeping all connecting wires as short as possible. Snap on the ON-OFF switch on Radio Control Box BC-722-B to the “ON” position and pull out the “PULL-TO-TALK” knob. Adjust the capacitor located near the antenna binding post for maximum deflection on the meter, using an insulated screw-driver. *With a $\frac{5}{16}$ ” wrench tighten the cap nut to lock the capacitor securely in place.* See Figs. 4 and 8. The “PULL-TO-TALK” knob should not be held out longer than is necessary to adjust the antenna tuning capacitor, as this shortens the life of the batteries. Disconnect the r-f meter and replace the antenna lead on binding post “A” on Mounting FT-295-B. The radio set is now ready for use in the glider. NOTE: A 0-50 ma r-f meter will be satisfactory for antenna capacitor adjustments in most cases. *If no other meters are available, the 50 ma r-f meter supplied as part of Test Equipment IE-17-B can be used for this adjustment. The range can be extended to 100 ma by shunting the meter with a 5 ohm non-inductive resistor.*

15. PORTABLE.—For use as a portable radio telephone, unsnap the buckle clasp on Mounting FT-295-B, push the connector release lever, and remove Radio Receiver and Transmitter BC-721-B.

Close the opening to the external-antenna receptacle by sliding the waterproof cover up over the opening, Fig. 2, and put the weatherproof socket cover, which is held to the hinged bottom cover by a chain, in position over the socket. The weatherproof cover must be pressed on very tightly taking care that it seats uniformly around the edges.

Unscrew the antenna cap located on top of the housing. This cap is attached to the housing by a small chain to prevent its loss. Screw the cap on the threaded metal stud on the top of the housing. This will prevent the cap from rattling against the housing when walking with the set. See that the chain IS NOT wrapped around the antenna rod and that there is no chance of it touching the rod.

Pull out the antenna gently until all four sections of the rod are fully extended. The antenna will then be about 39 inches long. The unit is now held in the left hand in the same manner as a telephone handset and is ready for use as a portable radio telephone set.

CAUTION: A stop at the lower end of the antenna rod prevents it from being pulled completely out of the case but the bottom section of the antenna must be fully extended since it operates the power switch on the chassis.

SECTION IV OPERATION

16. NORMAL OPERATION IN GLIDER

a. Plug the microphone into the microphone extension cord jack connecting to the MIC. jack in Radio Control Box BC-722-B. Any throat microphone model T-30 may be used.

b. Plug the headset into the headset extension cord jack connecting to the TEL. jacks on the ends of Radio Control Box BC-722-B. Use type HS-23 headsets.

c. To Start the Set.—Push the “ON-OFF” switch of Radio Control Box BC-722-B to the “ON” position. *Do not turn on radio set with “PULL-TO-TALK” knob in transmit position.*

d. To Receive.—The set is normally in the “receive” position. Volume is controlled by the INCREASE OUTPUT control knob. Leave the control in the maximum position until contact is established with the transmitter desired. It can later be adjusted for suitable volume. *NOTE: If it is desirable to hear communications from other gliders or from weak ground transmitters while in tow, the volume control should always be turned clockwise to the maximum volume position immediately after completing conversations with the tow plane. After tow is broken between the glider and the tow plane, the volume control should always be advanced to maximum volume position, as otherwise the pilot may not hear a transmitter trying to communicate with him from any great distance.* THE GLIDER RECEIVER IS PRE-TUNED CRYSTAL CONTROLLED, AND THEREFORE ANY TRANSMITTER USED TO COMMUNICATE WITH IT (SUCH AS IN THE TOWING AIRPLANE) MUST BE TUNED EXACTLY TO THE RECEIVER FREQUENCY. See paragraph 19 if reception is poor.

e. To Transmit.—Pull the “PULL-TO-TALK” control knob. This operates the change-over switch on the radio set chassis and converts the receiver into a transmitter. THE KNOB MUST BE HELD OUT DURING TRANSMISSION, AND RELEASED WHEN TRANSMISSION IS COMPLETED. *Best results will be obtained if the voice is held at a normal level when using a throat microphone. The microphone should be adjusted to a comfortable fit on the throat, neither too tight nor too loose. Speak clearly and distinctly and not too fast.*

f. To Turn the Set “OFF”.—Push the “ON-OFF” switch of Radio Control Box BC-722-B to the “OFF” position. THE SET SHOULD BE TURNED “OFF” WHEN THE GLIDER IS NOT IN USE. OTHERWISE THE BATTERIES IN THIS SET WILL RUN DOWN.

17. OPERATION AS A PORTABLE RADIO TELEPHONE.

a. Remove Radio Receiver and Transmitter BC-721-B from Mounting FT-295-B, as described in paragraph 1, d.

b. To Start the Set.—Remove the antenna cap by turning it counter-clockwise, and place it on the stud provided for it. The set is turned on when the antenna is fully extended. This is accomplished by a small lever attached to the antenna rod which operates the power switch on the radio chassis.

CAUTION: A stop at the lower end of the antenna rod prevents it from being pulled completely out of the case but the bottom section of the antenna must be fully extended, since it operates the power switch on the chassis.

c. To Receive.—The set is normally in the Receive position, so that the operator can hear another unit if it is transmitting on the same frequency. The antenna should extend above the head in an approximate vertical position. This is important for best reception and transmission.

d. To Transmit.—In order to transmit, the “press-to-talk” switch on the side of the housing must be depressed. This is done by the fingers of the hand holding the unit. The “press-to-talk” switch operates the change-over switch on the chassis which makes the necessary circuit changes to convert the receiver into a transmitter. The “press-to-talk” switch must be released when transmitting is completed, in order to receive. When speaking into the microphone, the speech level should be somewhat louder than normal and the operator should talk close to the microphone. For short distances between radio sets, it is advisable to speak at a lower level. The operator should speak clearly, and should make sure that the “press-to-talk” switch is depressed before starting to speak and that it is released immediately upon completion of conversation. There is a natural tendency to hold the switch down after the operator has finished speaking, and to forget to press the switch before he starts speaking. It is good practice to pause for a moment after pressing the “press-to-talk” switch.

e. To Turn the Set Off.—The set is turned off when the antenna is telescoped into the case. The bottom section of the antenna rod must be pushed into the case as far as it will go to turn the set off. The operator can hear the toggle switch snap over. The

antenna cap weatherproofing cover for sealing the telescopic antenna against weather conditions should be in place when the set is not in use. See Fig. 2.

f. Operation Over Long Periods.—When operating the portable radio set for long periods, it will be found less tiring to carry the set slung over the shoulder rather than in the hand. To carry it in this manner the strap must be lengthened. The strap can be lengthened by pulling the slide toward the antenna end of the case. The reverse action will tighten it. The left arm is then placed between the strap and the housing so that the set rests on the shoulder. The set is slung to the front, not the back of the operator. The set can then be held there with a slight pressure from the arm, or by permitting it to rest in the crook of the arm. When the operator is called, the sound will be loud enough for him to hear even though the earphone is several inches from his ear. The unit can then be brought into position for use.

18. OPERATION IN THE RAIN.—The portable radio set is designed to exclude water, but if operated during the rain it may be found that the water film covering the antenna insulator at the base of the antenna acts as a short between the telescopic antenna and case, making the set weak or inoperative. Wiping the insulator frequently with a dry cloth should improve operation.

CAUTION: Be certain that the external antenna receptacle cover is closed and weatherproofing cover in position over Socket SO-183 when the set is not in use.

19. POOR RECEPTION.

a. When operated in a glider, poor reception may be due to having the volume control turned so high that it causes distortion. The volume control must be carefully adjusted to obtain distortion-free reception when glider is in tow. When several gliders are flying in tow formation the shielding effect of one glider or more on the other may cause poor reception. The transmitter of the tow plane must also be tuned exactly to the glider receiver frequency for best operation.

b. When operated as a portable radio telephone, poor reception may be caused by signal absorbing objects, such as steel buildings, trees, hills, power and telephone lines, and large metal objects, between the two units. The straight line distance between units should be as clear as possible of such objects. Moving one or both units over to new locations will often improve the operation.

20. LOCATING TROUBLE.

a. If the set does not work when installed in a glider, that is, no sound is heard in the pilot or co-

pilot's headset, first make certain that the switch is "ON" and that the volume control is turned "full-on" in a clockwise direction. Then check to see that the headset and microphone plugs are inserted in their proper receptacles in Radio Control Box BC-722-B. Check Cordage CO-220, and make sure that Plugs PL-203 and PL-237 are properly inserted into Mounting FT-295-B and Radio Control Box BC-722-B. Check the antenna lead-in to see that it is connected to the antenna binding post on Mounting FT-295-B. Also check the adjustment of the "PULL-TO-TALK" control shaft as specified under paragraph 12. Be sure that the hinged cover on the radio housing is fastened tightly. If the set still does not work, remove Radio Receiver and Transmitter BC-721-B from Mounting FT-295-B and test as outlined in part b, paragraph 20.

b. If the set does not work as a portable radio telephone when the antenna is extended, that is, no sound is heard in the earphone, check to see that the bottom section of the antenna extends out of the case to its full length. This is necessary to operate the power switch on the chassis.

If the antenna rod is extended properly and the set still does not work, check to see that the batteries are placed in the compartment properly.

c. If the unit still does not work, refer to Maintenance Section for further corrective measures.

d. Operating the portable unit as high as possible, as on top of a hill or building, will help increase the distance of operation. Be sure that the antenna is fully extended, held in a vertical position and clear of obstructions for several feet around it. When operating the unit in the underbrush, keep the antenna from coming in contact with branches or green foliage of any kind. Precautions should be taken particularly in the early morning when the dew is on the ground, or after a rainfall as conditions of this kind may render the unit inoperative.

21. USABLE COMMUNICATION DISTANCE.—The unit is designed to operate over distances from 100 feet to 1 mile when operated as a portable radio telephone. The dependability of operation at the greater distances will depend on the terrain and the freedom from signal absorbing objects, such as steel buildings, trees, hills and telephone and power lines between the two sets. This is particularly true for units operating at the higher frequencies in the band.

When installed in a glider, the usable communication distance is somewhat increased because of the larger antenna and greater freedom from signal absorbing objects.

22. OPERATION COMMON TO GLIDER AND PORTABLE RADIO TELEPHONE.

a. Change of Frequency.—Changing the operating frequency of the unit requires a change of the two crystals and the coils. Coil and crystal equipment is available to cover the frequency range of 3.5 megacycles to 6 megacycles if required. Special equipment is required for retuning of the sets and a trained technician must do the job. The realignment and coil changing procedure will be found in the Maintenance section of this book.

b. Replacement of Batteries.—See procedure given in Section II, paragraph 10. Both batteries should be replaced even though one may be in better condition than the other.

NOTE: When sets are to be placed in storage for long periods of time, the batteries should be removed from the case. This will prevent the batteries from be-

coming wedged in the battery compartment, should they swell when aging.

c. Netting.—For a two-way conversation, two units adjusted to operate on the same frequency are required. Two units operating at different frequencies will be unable to converse with each other.

More than two operators can engage in conversation by the use of more units operating on the same frequency. Because of the receiver arrangement used, it is possible to operate several receivers at the same frequency and in close proximity, without interference.

d. There are no limitations on the number of glider radios that may be operated together without interference in any one flight group or series of flight groups. However, it will be necessary to restrict communication to a minimum as more than one glider transmitting at the same time on the same frequency is apt to cause confusion in orders.

SECTION V MAINTENANCE

23. LOCATING TROUBLE WHEN SET DOES NOT OPERATE.—Usually this is a sign of weak batteries or a burned out tube, although this could be caused by the batteries being placed in the battery compartment with negative ends up.

24. REPLACEMENT OF THE BATTERIES.—See paragraph 10, Section II.

25. REPLACEMENT OF THE TUBES.—Remove the chassis from the housing. To do this unlatch the bottom cover of the housing and remove the batteries. Disconnect the microphone and earphone plugs from the terminal board on the ends of the chassis. Remove the mounting screw in the top cover of the housing, and the chassis can be slid out of the bottom of the housing. Lift the clamp at the top of the tube and remove the shield, if there is one. Insert a narrow rod through the bottom in the center of the tube socket and gently force the tube out. A small narrow blade screw driver will be found useful for this purpose. When replacing the tube, be sure that you have the right type, that the base of the tube is so oriented that the pins fit into the socket properly, and the pins are straight. The wide space between pins No. 1 and No. 7 of the tube can be used as a guide to line the tube with the socket. See Fig. 22.

26. REPLACEMENT OF THE ANTENNA COIL.—The antenna coil is of the “plug-in” type. It can be easily removed and replaced. See Fig. 15.

27. REPLACEMENT OF THE R-F TANK COIL.—To remove the coil, loosen the screw holding down the spring clip on top of the coil; then swing the clip free of the coil. The coil can then be lifted out of the socket. When replacing, fit the coil carefully over the two pins projecting up from the socket so that the pins fit into the holes in the coil form and the coil adjustment fits into the hole in the socket. Gently press the coil into the socket and replace the spring clip on top of the coil. See Fig. 15.

28. REPLACEMENT OF THE MICROPHONE.—Remove the batteries, cardboard separator, and chassis from the case. Then unscrew the bakelite microphone cover on the housing. The unit can now be lifted out of the housing. To detach the microphone unit from the housing, it will be necessary to remove the screw which grounds one of the two leads to the housing. The lead with the connecting plug (green dot), which fits into the jack on the terminal board, is withdrawn through the hole in the housing. See Fig. 5 and Fig. 6.

29. REPLACEMENT OF THE EARPHONE.—The earphone is replaced in the same manner as the microphone.

30. REMOVAL AND REPLACEMENT OF THE CRYSTALS.—The crystals are mounted in “plug-in” type holders. To remove a crystal, lift up the clamp located on top of the crystal holder. This clamp pivots on a stud fastened to the chassis. Place a screw driver between the crystal holder and the socket and gently pry it up. See Fig. 15.

The receiver crystal, which is 455 kc above the frequency of the transmitter crystal, is placed in the crystal socket marked “REC.” and should be placed so that the arrow on the holder points in the same direction as the arrow on the socket.

The transmitter crystal should be placed in its socket in the same manner as that of the receiver crystal.

31. POOR RECEPTION AND TRANSMISSION.—If the distance between units in operation is within the limits of 100 feet to one mile, and the transmission is poor, the batteries may be weak. The batteries are designed to give about 10 hours of operation, assuming that the unit is on for long periods of time, and that the operator is transmitting a great deal. They will last much longer if used intermittently. A sign of weak batteries is a very low noise level in the earphone when the set is in the Receive position with no incoming signal.

a. Set Inoperative.

(1) If the batteries are placed in the battery compartment, with the negative ends up, the set will not operate. If the batteries are inserted correctly and the set does not operate, the batteries may be dead. Replace them with a new set of batteries.

(2) A tube may be burned out or shorted. Remove the chassis from the housing. See paragraph 25, Section V. Locate the defective tube and replace it. Install the chassis in the housing. Take care that the chassis fits between the guides provided for it in the case. If the set still does not operate, it should be turned over to a maintenance man for further inspection.

32. ALIGNMENT PROCEDURE USING TEST EQUIPMENT IE-17-B.

a. Test Equipment Required.

- 1 Test Equipment IE-17-B consisting of:
 - (a) Test Stand FT-252-B includes dummy antenna

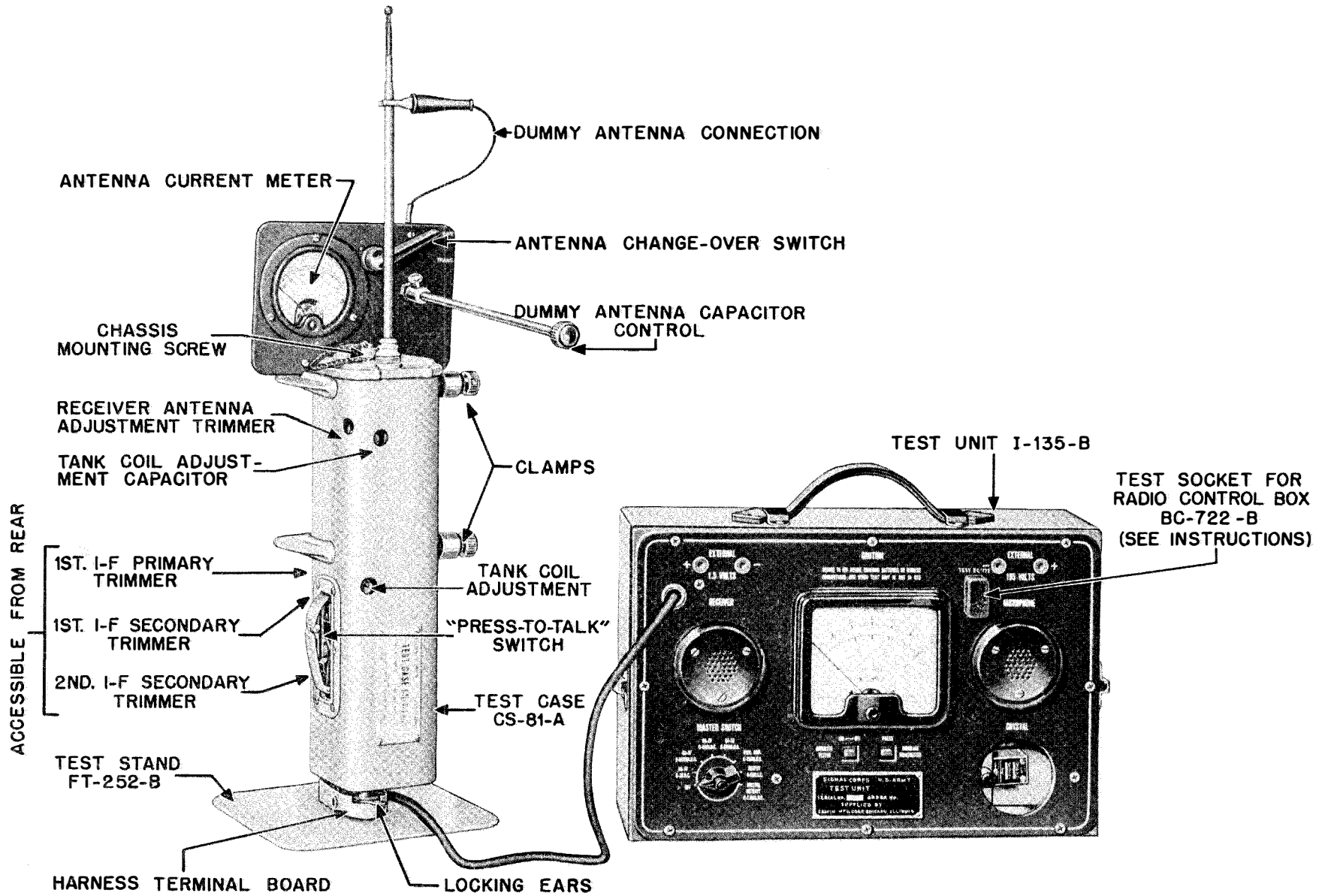

FIG. 12. TEST UNIT EQUIPMENT IE-17-B, SET-UP FOR RECEIVER ALIGNMENT

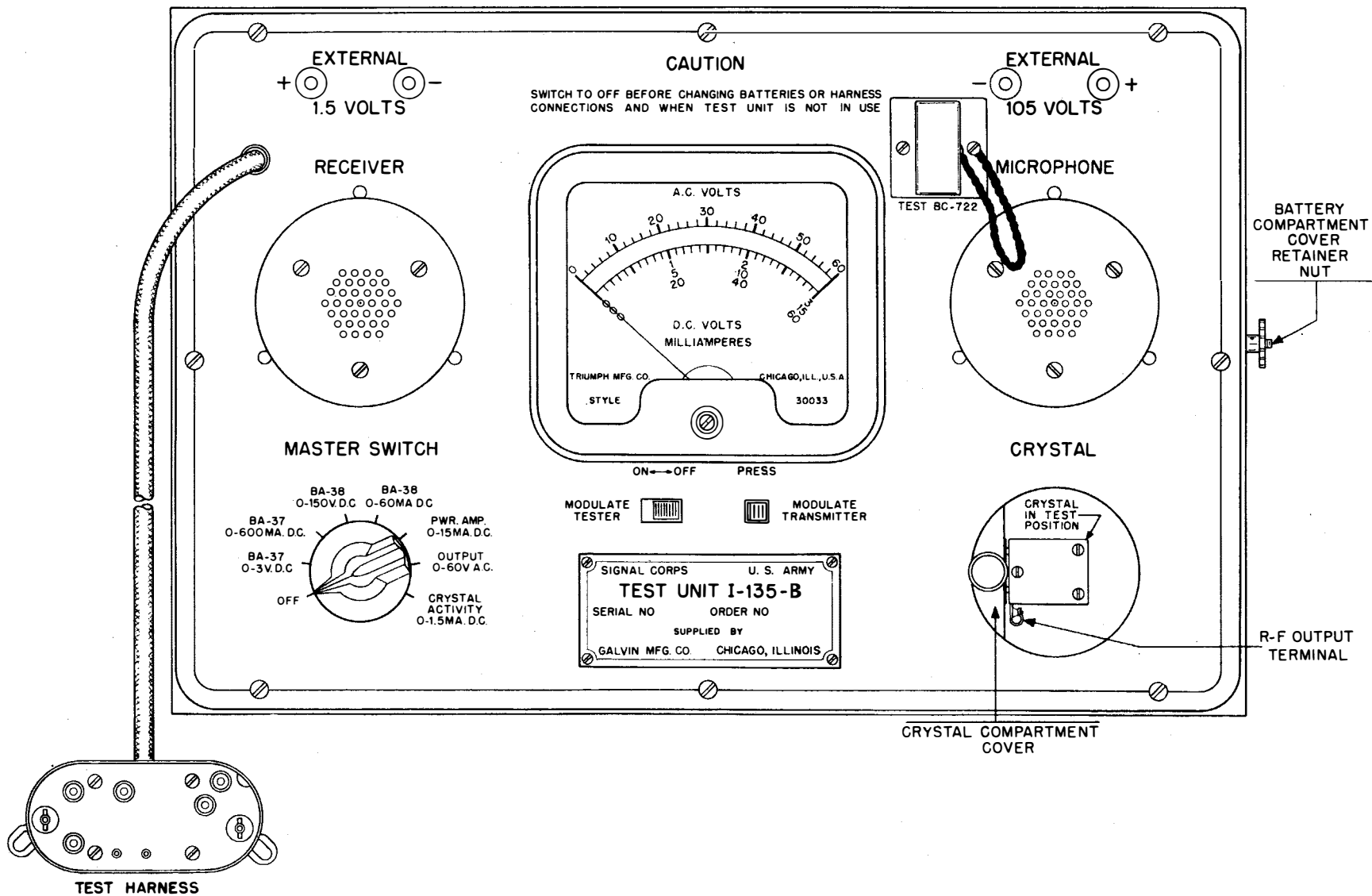

FIG. 13. TEST UNIT I-135-B

- (b) Test Case CS-81-A
- (c) Test Unit I-135-B contains multi-range meter, harness, r-f and a-f oscillators, battery connections, and instruction book.

b. Test Case CS-81-A.—As the tuning adjustments are inaccessible because of their location on the chassis, which is covered by the case or housing, special apparatus (Test Equipment IE-17-B) is required to make these adjustments. See Fig. 12. Test Case CS-81-A is similar to a chassis housing except for the holes that have been provided to permit access to the adjustments. This apparatus permits tuning the set under conditions identical to those of normal operation. The tuning adjustments should not be made on the set without the housing around the chassis, because the set would become detuned when inserted into the housing. Detuning or misalignment would result from the additional capacity introduced into the circuit by the housing.

c. Test Stand FT-252-B.—The test stand contains clamps to hold the unit, a 50 ma r-f milliammeter to measure antenna current, and a receiver and transmitter dummy antenna, consisting of a receive-transmit switch, a 56 ohm resistor and a variable capacitor of 8 $\mu\mu\text{f.}$ maximum capacity.

d. Test Unit I-135-B.—See Fig. 13. This unit is a multi-range voltmeter and milliammeter, a crystal tester, and an r-f and a-f signal source. Test Unit I-135-B is used for the measurement of battery voltage, battery current, r-f amplifier plate current, audio output voltage, and crystal activity. It is used as a modulated r-f signal source for the alignment of the receiver and as an a-f signal source for determining the modulation capability of the transmitter.

The r-f signal source is a Pierce crystal oscillator and makes use of the transmitter crystal contained in Radio Receiver and Transmitter BC-721-B or one of the same frequency. It generates a signal of the carrier frequency. This r-f oscillator also serves to check both the receiver crystal and the transmitter crystal for activity.

The a-f signal source is a Colpitts oscillator generating a signal of 1000 c.p.s. This tone is used to modulate the r-f oscillator and can also be applied to the microphone input terminals of the transmitter to test for modulation capability.

A test harness attached to the test unit provides the means of connecting to the chassis. See part e (4) of this paragraph.

An insulated screwdriver is attached to the cover of the test unit and is to be used for alignment purposes.

Compartments are provided in the test unit for "A" Battery BA-37 and "B" Battery BA-38 to permit these batteries to be tested under load.

Connections are provided for the use of external batteries with this test unit. A heavy duty 1.5 volt battery (Battery BA-23 or Battery BA-35) and a heavy duty 90 volt battery (two Battery BA-26 or two Battery BA-36) will be satisfactory for all alignment and testing purposes. Battery BA-37 and Battery BA-38 part of Radio Receiver and Transmitter BC-721-B can also be used for this purpose but are not recommended due to their short life under these conditions.

The positions of the "MASTER SWITCH" of the test unit are as follows:

(1) "OFF" which disconnects external "A" battery or Battery BA-37 and external "B" battery or Battery BA-38 from the chassis of Radio Receiver and Transmitter BC-721-B and from the r-f and a-f oscillators in Test Unit I-135-B. The radio set and oscillator are "ON" in all other positions of the "MASTER SWITCH."

(2) "BA-37, 0-3V. D.C.," which indicates on the meter the voltage of external "A" battery or Battery BA-37 when the radio set is in either the "receive" or "transmit" position.

(3) "BA-37, 0-600 MA. D.C.," which indicates on the meter the current drain of external "A" battery or Battery BA-37 when the radio set is in either the "receive" or "transmit" position.

(4) "BA-38, 0-150 V. D.C.," which indicates on the meter the voltage of external "B" battery or Battery BA-38 when the radio set is in either the "receive" or "transmit" position.

(5) "BA-38, 0-60 MA. D.C.," which indicates on the meter the current drain of external "B" battery or Battery BA-38 when the radio set is in either the "receive" or "transmit" position.

(6) "PWR. AMP., 0-15 MA. D.C.," which indicates on the meter the r-f power amplifier plate current when the radio set is in "transmit" position.

(7) "OUTPUT 0-60 V. A.C.," which indicates on the meter the audio output voltage of the radio receiver; the meter is connected across the earphone in the test unit.

(8) "CRYSTAL ACTIVITY, 0-1.5 MA. D.C.," which indicates on the meter the grid current of the crystal oscillator to show condition of crystal. The "MODULATE TESTER" switch must be "OFF" when crystal activity is being checked.

The switch marked "MODULATE TESTER" is used to modulate the r-f oscillator with a 1000 c.p.s. tone when the test unit is to be used for receiver alignment purposes.

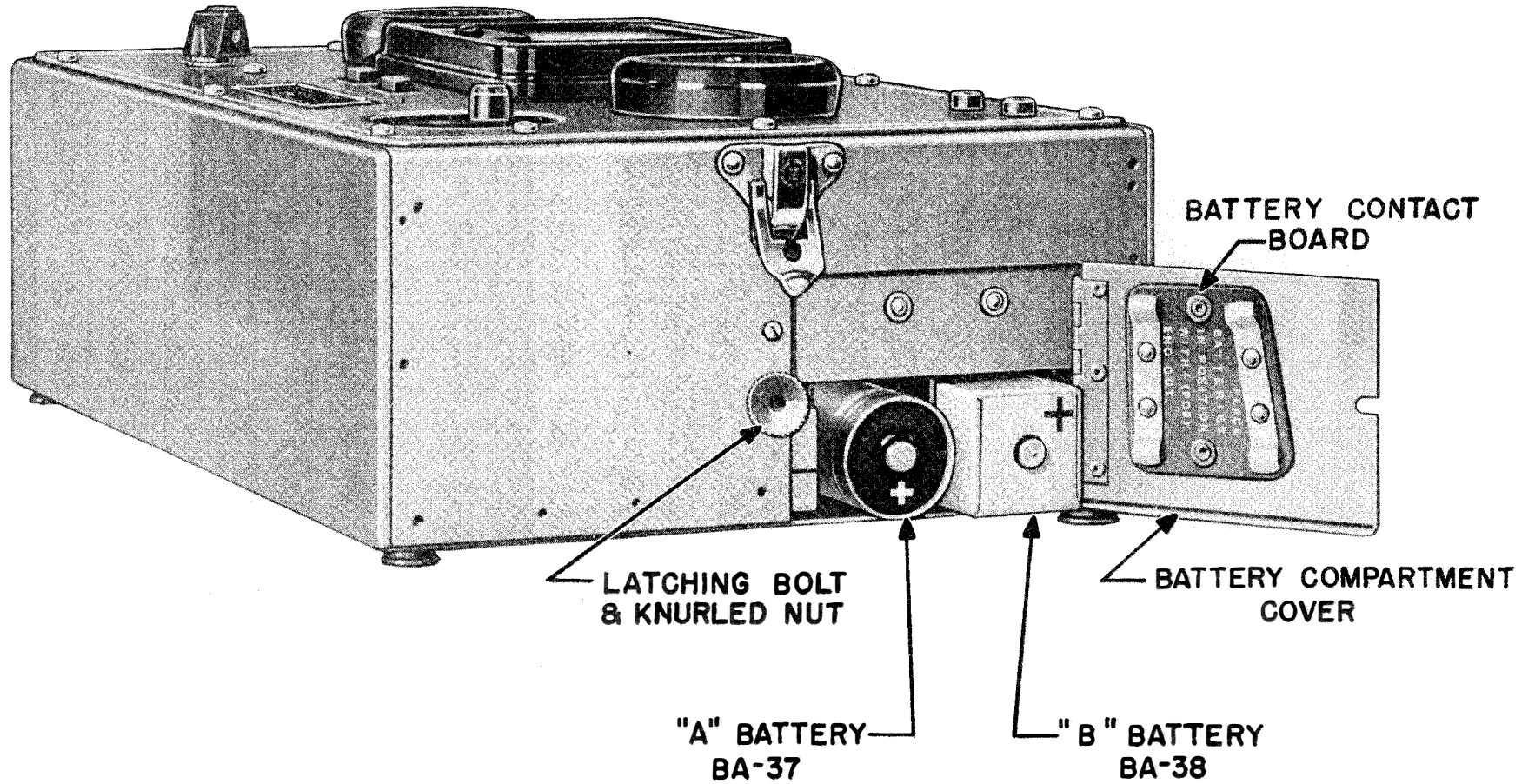

FIG. 14. TEST UNIT I-135-B SHOWING BATTERY COMPARTMENT

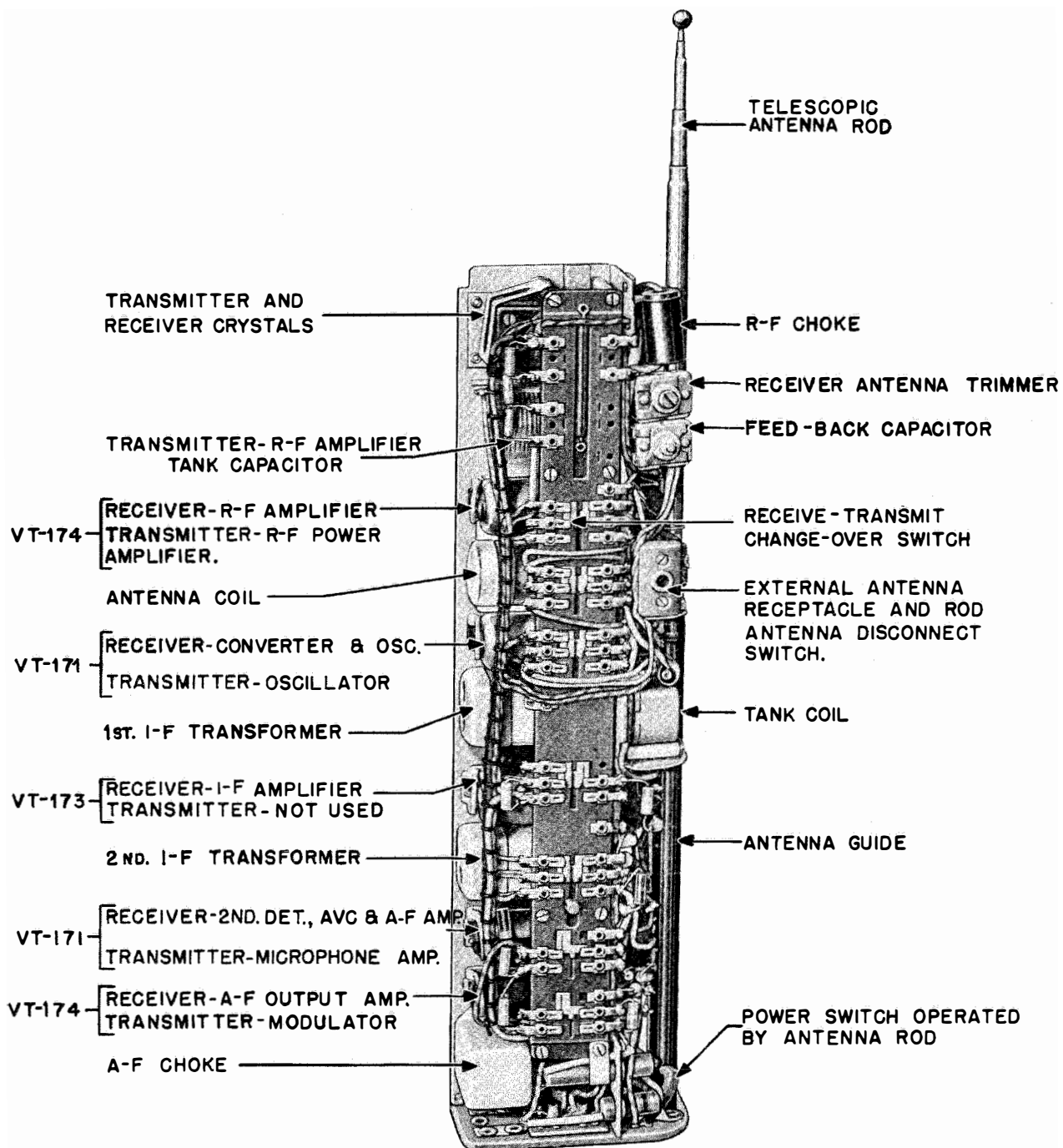

FIG. 15. RADIO RECEIVER AND TRANSMITTER BC-721-B, CHASSIS (FRONT VIEW)

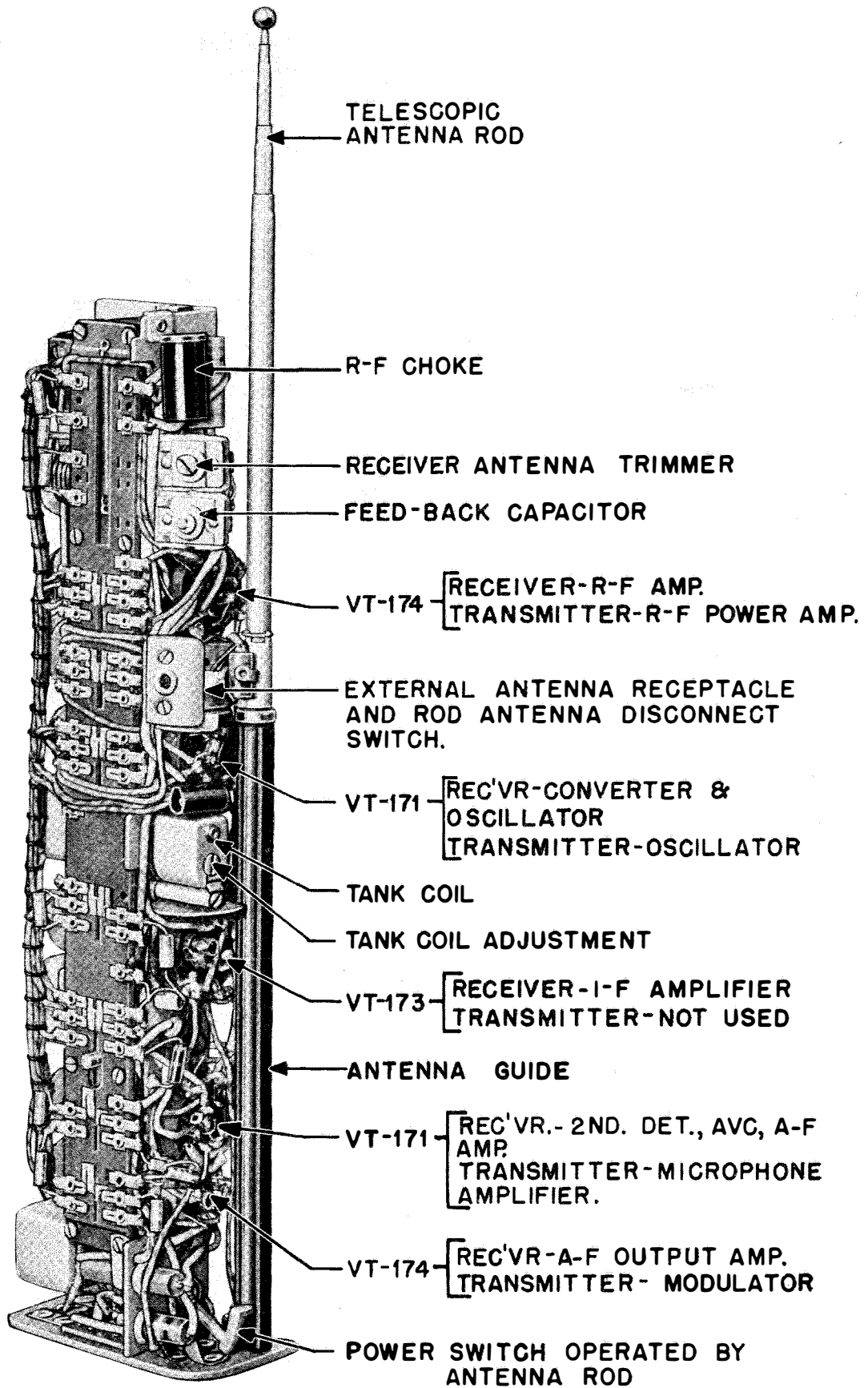

FIG. 16. RADIO RECEIVER AND TRANSMITTER BC-721-B, CHASSIS (BOTTOM VIEW)

The switch marked "MODULATE TRANSMITTER" applies a 1000 c.p.s. audio voltage across the microphone input circuit of the transmitter as a test of the modulation capability of the transmitter. Note: The "MODULATE TESTER" switch must be "ON" and a crystal must be in place in the compartment socket when this test is made.

Test Unit I-135-B also contains an earphone and microphone which are mounted in the front panel of the case. These can be used to listen to the audio output of the receiver or to modulate the transmitter by speaking into the microphone.

An eight contact socket marked "Test BC-722" is provided for testing Radio Control Box BC-722-B. The dummy plug must be in the socket at all times except when the radio control box is to be tested. All alignment and other tests are made with the dummy plug in place.

e. Setting up the Alignment Equipment.

(1) Remove the chassis of Radio Receiver and Transmitter BC-721-B to be aligned from its housing. To do this, unlatch the bottom cover of the housing and remove the batteries. These batteries should be placed aside for test. Then disconnect the microphone and earphone plugs from the terminal board on the end of the chassis. Now remove the screw in the top cover of the housing and the chassis will slide out of the bottom of the housing.

(2) Remove the transmitter crystal from the chassis or use an extra crystal of the exact carrier frequency and place it in the crystal socket in the front panel compartment of the test unit. See Figure 13. Set the "MASTER SWITCH" of the test unit to the "OFF" position.

(3) Place the chassis into Test Case CS-81-A housing. The chassis must be inserted into the test case through the bottom as is done when inserting the chassis into its own housing. Take care that the chassis fits between the guides provided for it in the case. It should not be necessary to force the chassis. If force is necessary, withdraw the chassis and check to see that no parts are catching on the test case or that the chassis has not jumped the guides. Slip the top cover over the antenna rod and fasten the chassis to it with the knurled mounting screw provided. The chassis will now be held securely in the test case. *Now remove the plate current meter jumper from the terminal board at the end of the chassis.*

CAUTION: DO NOT MISPLACE. THIS JUMPER MUST BE REPLACED AFTER ALIGNMENT TESTS.

(4) Attach the terminal board of the harness to the terminal board of the chassis so that the two small pins on the harness terminal board fit into the plate current meter jacks, and that the two large

locking pins, one on each end of the terminal board, fit into the holes provided for them. Lock the two terminal boards together by a sideward movement of the levers attached to the locking pins.

(5) Next, clamp Test Case CS-81-A into Test Stand FT-252-B with the antenna end up, and the housing in such position that the change-over switch is opposite the left side of the operator as he faces the stand. See Figure 12. The upper clamp should grip the housing on the edges of the top cover. The lower clamp should not be made too tight as the pressure may crack the housing.

(6) Make certain that the "MASTER SWITCH" of the test unit is in the "OFF" position. Then connect external 1.5 volt and 90 volt heavy duty batteries of the type described in paragraph 32, d.

f. Transmitter Crystal Activity Test

Be sure that the transmitter crystal has been properly placed in the crystal socket of the test unit. Then turn the "MASTER SWITCH" to the "CRYSTAL ACTIVITY" position. The meter should read between .3 and .8 milliamperes. The "MODULATE TESTER" switch must be in the "OFF" position for this test. If the crystal activity reading is lower than .3 ma., the crystal shall be replaced and the defective unit returned to the depot for servicing. Before replacing a crystal unit for poor activity, be sure that the external battery voltages applied to the test unit are 1.5 and 90 volts. *The above tests apply equally well to receiver crystals.* Leave a good transmitter crystal of the proper frequency in place in the test unit for receiver alignment tests.

g. Procedure for Receiver Alignment.

(1) Extend the antenna rod to its full length, 39 inches above the top cover of the test case. This will turn on the radio chassis power switch. The "press-to-talk" switch on the test case must be out for all receiver alignment tests.

(2) Turn the "MASTER SWITCH" on the test unit to "BA-37, 0-3 V. D.C.," position and observe the meter reading. The normal reading is between 1.4 and 1.5 volts, and the reading is the filament or "A" battery voltage when the radio set is operating as a receiver. If it is less than 1.35 volts, the external heavy duty 1.5 volt battery must be replaced.

(3) Turn the "MASTER SWITCH" on test unit to "BA-37, 0-600 MA. D.C.," position and observe the meter reading. The normal reading is approximately 350 ma. This reading is the current drain on the "A" battery.

(4) Turn the "MASTER SWITCH" on test unit to "BA-38, 0-150 V. D.C.," position and observe the meter reading. If this reading is below 85 volts, the external heavy duty 90 volts battery will have to be

replaced. This reading is the "B" battery voltage when the radio set is operating as a receiver.

(5) Turn the "MASTER SWITCH" on test unit to "BA-38, 0-60 MA. D.C.," position and observe the meter reading. The normal reading is approximately 14 ma. when the radio set is operating as a receiver.

(6) The receiver is now ready for alignment. Be sure that a good transmitter crystal of the proper frequency is in place in the test unit. The preceding activity check of the transmitter crystal will assure that a radio frequency signal is being generated.

(7) Set the "MODULATE TESTER" switch to "ON." The 1000 c.p.s. tone will now modulate the carrier signal.

(8) Turn the "MASTER SWITCH" to "OUTPUT, 60 V. A.C." position. A reading should now be indicated on the meter and a 1000 c.p.s. tone should be heard in the earphone of the test unit.

(9) The r-f signal for alignment is fed into the receiver by radiation from the compartment in the test unit in which the crystal is located. The slide cover of the crystal compartment acts as a radiation control preventing the signal from radiating when closed and allowing maximum radiation when open. If the set is badly out of alignment, the r-f signal picked up by the receiver may not be sufficient to give a reliable audio voltage reading on the meter (OUTPUT 0-60 V. A.C. position). For such a condition, connect a short piece of wire to the Fahnestock clip marked "R.F. OUTPUT". This clip is located in the crystal compartment of the test unit. The wire will act as an antenna and increase the radiation of the r-f signal. Varying the position of this wire with respect to the antenna of the radio set or varying the length of the wire will control the strength of the signal radiated. It may be necessary in extreme cases of misalignment that the wire connected to the "R-F OUTPUT" terminal will have to be wrapped a couple of turns around the radio set antenna.

(10) The test case shall be grasped with one hand during all the alignment tests on the receiver.

(11) The location of the tuning adjustments on the radio chassis are shown in Figs. 12, 15, and 16. With the insulated screwdriver, turn the "receiver antenna adjustment trimmer" clockwise. Notice the effect of this adjustment on the output meter reading. If the meter reading increases, continue to tighten the screw until a maximum reading is obtained. If the reading decreases, turn the screw counter-clockwise until a maximum reading is obtained. Be careful not to tighten the screw after it begins to turn hard as the threaded base of the trimmer will be stripped. The setting of the trimmer screw for maximum audio output should fall somewhere between the point of

hard tuning and that of minimum pressure on the upper plate of the trimmer. If the maximum is not reached in these limits of the screw adjustment, try another antenna coil. *If the set appears to be badly out of alignment, see paragraph 33.*

Be sure that the r-f signal is not strong enough to cause overloading of the receiver. If this condition exists, adjustment of the antenna trimmer will have little or no effect on the audio output reading. Best results will be obtained if the r-f input is adjusted so that the meter reading on the 60 volt scale does not exceed 10 volts, although satisfactory results may be obtained with readings up to 20 volts.

(12) *With the insulated screwdriver*, turn the "tank coil adjustment" screw for maximum output using the same method employed in step (11). This screw which is made of bakelite fits into a powdered iron core which is threaded. The movement of the screw changes the position of the core in the coil. If the screw is turned too far clockwise, the core will ride up against the screw head and threads in the core will be stripped. If the screw is turned too far counter-clockwise, the core will come in contact with the coil socket and further turning will again strip the core treads. The screw setting for maximum output should fall somewhere between these two limits of adjustment. If it does not, a wrong tank coil may be in the set.

(13) Turn the "MASTER SWITCH" to "OFF." Remove the transmitter crystal from the test unit. Telescope the rod antenna and remove the test harness and the knurled fastening screw from the chassis in the test case. Then slide the chassis out of the test case and remove the receiver crystal and install it in the test unit. Put the transmitter crystal back into the chassis and put the chassis back in the test case. Attach top cover and harness terminal board. Put test case in place on the test stand. Then test the receiver crystal for activity in the same manner as for the transmitter crystal. *Leave a good receiver crystal in place in the test unit while making tests on the transmitter portion of the radio set.*

h. Procedure for Transmitter Adjustment.

(1) The test case must be grasped with one hand during all following alignment adjustments to the transmitter. The "MODULATE TESTER" switch should be "OFF" unless otherwise specified.

(2) Extend the antenna of the radio set to its full length. This will operate the power switch in the radio set chassis.

(3) Turn the "MASTER SWITCH" on test unit to "BA-37, 0-3V. D.C." position and observe the meter reading. The normal reading is between 1.4 and 1.5 volts, and this reading is the filament or "A" battery voltage when the radio set is operating as a

transmitter. If this reading is less than 1.35 volts, the external heavy duty 1.5 volt battery should be replaced.

(4) Turn the "MASTER SWITCH" on test unit to "BA-37, O-600 MA. D.C." position and observe the meter reading. The normal reading is approximately 300 ma. This reading is the current drain on the "A" battery, when the radio set is operated as a transmitter.

(5) Turn the "MASTER SWITCH" on test unit "BA-38, O-150 V. D.C." position and observe the meter reading. If this reading is below 75 volts, the external heavy duty 90 volt battery will have to be replaced. This reading is the "B" battery voltage when the radio set is operating as a transmitter.

(6) Turn the "MASTER SWITCH" on test unit to "BA-38, O-60 MA. D.C." and observe the meter reading. The normal reading is approximately 30 ma. when the radio set is operated as a transmitter.

(7) Turn the "MASTER SWITCH" on test unit to "PWR. AMP." position. Adjust the "tank coil adjustment capacitor" for *minimum* current reading on the meter in the test unit. The normal reading in this position is approximately 7 ma. See Figure 12 for location of "tank coil adjustment capacitor." *Be sure to grasp the test case with one hand during this test.*

(8) Telescope the upper three sections of the antenna rod leaving only the bottom or fourth section fully extended from the housing. Next, clip the "dummy antenna connection" to the upper part of the antenna rod. See Figure 12. Set the antenna switch on the panel of Test Stand FT-252-B to "TRANS." position, and then using the insulated shaft, adjust the "dummy antenna capacitor control" for *minimum current reading on the meter in test unit* (approximately 7 ma. meter in PWR. AMP. position). This adjustment of the dummy antenna capacity for minimum power amplifier plate current is necessary to compensate for the change in antenna capacity due to telescoping the upper three sections of the antenna rod. Observe the antenna current reading on the R.F. meter on Test Stand FT-252-B. This should be approximately 15 ma. and represents the unmodulated antenna current.

(9) Place the "MODULATE TESTER" switch to "ON" position and press the "MODULATE TRANSMITTER" button on the test unit. This applies a .2 volts, 1000 c.p.s. audio signal across the microphone terminals. Note the rise in the antenna current meter reading when the modulated signal is applied. This rise should be at least six per cent over the unmodulated current reading. A six per cent increase in antenna current indicates fifty per cent modulation. For example, assume that the unmodu-

lated antenna current is 20 ma. and that the modulated current is 22 ma.

The increase in current is then:

$$22 - 20 = 2 \text{ ma.}$$

The percentage increase will be:

$$2/20 \times 100 = 10 \text{ per cent.}$$

Another method is to divide the antenna current obtained with modulation by the antenna current without modulation; the answer should be greater than 1.06. For example, take the values of current previously given. Dividing the modulated current by the unmodulated current gives $22/20 = 1.10$.

Further checks on modulation may be made by whistling into the microphone or holding a sustained note. The modulation rise should be substantially greater. Note: "MODULATE TRANSMITTER" button must not be pressed during this test.

33. PROCEDURE IF BADLY OUT OF ALIGNMENT.—If the i-f transformers have been badly out of alignment, it may be impossible to get a carrier frequency signal through the receiver as outlined in "Procedure for Receiver Alignment," paragraph 32g. For such a condition, the i-f transformers must be re-aligned. There are two ways of doing this, the most satisfactory being to use a 455 KC signal generator connected to the signal grid of the mixer tube while the second method makes use of Test Equipment IE-17-B.

a. Procedure for I-F Alignment using Signal Generator.

(1) Remove the chassis from the test case and fasten it to the top cover of the housing with the mounting screw. Then place the chassis in the test stand in the same relative position as when in the test housing, and hold it there by gripping the housing cover with the upper clamp of the test stand. Leave the test unit connected to the chassis.

(2) Connect the ground lead of the signal generator to Test Stand FT-252-B. Connect a .05 uf capacitor in series with the output lead of the signal generator and connect the other end of the capacitor to the No. 6 pin of Tube VT-171, used as a converter-oscillator. Set the signal generator frequency accurately to 455 kc by means of Frequency Meter Set SCR-211. Set the "MASTER SWITCH" of the test unit to "OUTPUT O-60 V. A.C." position. Then adjust the generator output until a 10 volt reading is obtained on the output meter. Considerable generator output will be required when the set is badly out of alignment.

(3) Adjust the trimmer on the second i-f transformer for maximum audio output. Reduce the generator output as the audio output increases above 10 volts. Next, peak the secondary on the first i-f

transformer and then peak the primary trimmer. After these adjustments have been made, put the chassis back into Test Case CS-81-A and align the set as given in the regular alignment procedure, paragraph 32g.

b. Procedure for I-F Alignment, using Test Equipment IE-17-B.

(1) This method of alignment is satisfactory as long as the transmitter crystal and receiver crystals in the set are exactly 455 kc apart.

(2) If the regular alignment procedure described in paragraph 32g has been followed, and no readable audio voltage has been obtained on the "OUTPUT O-60 V. A.C." position of the test unit meter, first make sure that a maximum r-f signal is being radiated. This can be assured by connecting a short length of wire to the "R.F. OUTPUT" terminal of the test unit and placing this wire close to the receiver antenna.

(3) Then with the "MASTER SWITCH" of the test unit on "OUTPUT 60 V. A.C.," adjust the second i-f secondary trimmer for maximum output, then the first i-f secondary trimmer next, and the first i-f primary trimmer last. See Fig. 12. All i-f trimmers are adjusted for peak output meter reading. As the i-f trimmers are aligned, loosen the signal coupling to the receiver antenna so the maximum audio output reading of the meter is not over 10 volts. This is necessary to prevent overloading the receiver and consequently poor alignment of the i-f circuits. The above alignment adjustments must be performed very carefully for good results.

(4) After the i-f alignment adjustments have been made, complete the regular alignment procedure by adjusting the "receiver antenna adjustment trimmer" and the "tank coil adjustment" as given in paragraph 32g.

34. CHANGE OF FREQUENCY.—To cover the range of frequencies from 3.5 to 6 megacycles, antenna coils, tank coils, and crystals are available. Each coil is marked with its frequency and part number so that errors of coil selection will be minimized.

To change the operating frequency of Radio Receiver and Transmitter BC-721-B, obtain a "Coil and Crystal Equipment" of the desired frequency. The "Coil and Crystal Equipment" comes in an individual carton marked with the frequency and contains the transmitter crystal, the receiver crystal, the antenna coil, and the tank coil.

The antenna coil is larger and of a different shape than the tank coil. Its base connections also differ, so there can be no possibility of getting the coils in the wrong sockets. Both coils are of the plug-in type to simplify replacement. See Fig. 15, and Fig. 16.

Remove the present coils and crystals from their sockets. The crystal clamp must be lifted before removing the crystals in the set. Each crystal is then easily removed by inserting a small screwdriver between the crystal holder and socket and prying. Now place the new coils in their respective sockets. Then put the crystals in their proper place in the crystal socket. The transmitter crystal should be placed in the socket so that the frequency printed on the metal face of the crystal holder shows through the opening in the metal chassis. The receiver crystal should be placed in the socket with the printed side facing out so that it can be seen. In any event, the arrow on top of the crystal holders and the arrow on the socket must point in the same direction. Replace the crystal clamp.

Proceed with the alignment of the receiver and transmitter as indicated in paragraph 32.

35. TEST PROCEDURE FOR RADIO CONTROL BOX BC-722-B AND CORDAGE CO-220.

a. A performance test can be made on Radio Control Box BC-722-B through the use of a good radio receiver and transmitter and Test Equipment IE-17-B.

b. First remove the radio chassis from the housing and insert it into Test Case CS-81-A, first making sure that both the receiver and transmitter crystals are in place on the radio chassis. Then connect the harness and terminal board of Test Unit 1-135-B to the chassis, and place the case on the test stand. The radio set in the test case must be in the receive position and its antenna should not be pulled out. Remove the dummy plug from the socket on test unit marked "Test BC-722" and plug in Radio Control Box BC-722-B.

c. With the switch on Radio Control Box BC-722-B in the "OFF" position, turn the "MASTER SWITCH" of the test unit to "BA-38, O-60 MA. D.C." position. The meter of the test unit should read zero. With the "ON-OFF" switch in the "ON" position, the meter of the test unit will read the "B" current drain of the radio set when operating as a receiver. This value is approximately 14 milliamperes. This test indicates that the "B" battery circuit in the control box is satisfactory.

d. Turn the "MASTER SWITCH" of test unit to the "BA-37 O-600 MA. D.C." position. With the "ON-OFF" switch of the control box in the "OFF" position, there should be no reading on the meter. With the switch of the control box in the "ON" position, the meter should read the "A" battery current drain of the radio set when operating as a receiver. This value is approximately 350 milliamperes. This test indicates that the "A" battery circuit in the control box is satisfactory.

e. Plug Headset (HS-23) into the jack marked "Tel." on the control box. Vary the volume control from minimum to maximum position. This should vary the volume of the background noise of the receiver. Test both headset jacks in this manner. This test indicates that both the volume control and headset jacks are satisfactory. The control box switch should be in the "ON" position, and the rod antenna extended for this test.

f. Turn the "MASTER SWITCH" to "OFF." Attach the "dummy antenna capacitor" clip to the fourth section of antenna rod, leaving the first three sections telescoped. See Fig. 12. The "press-to-talk" switch must be in transmit position. Turn the "MASTER SWITCH" to "PWR. AMP." position and adjust the "dummy antenna capacitor" for *minimum* current reading, approximately 7 ma. Observe the antenna current meter reading. This should be approximately 15 ma., and is the unmodulated antenna current.

g. With the transmitter operating properly, the control box switch "ON," and a throat microphone plugged into the jack marked "MIC.," produce a steady frequency tone in the throat microphone by either whistling or holding a sustained note by voice. Be sure to whistle loud enough to cause the antenna current meter reading to rise. Observe the modulated antenna current reading. The modulated antenna current reading should be 15% higher than the unmodulated antenna current meter reading.

h. The above tests may be repeated using interconnecting Cordage CO-220, with plugs attached, between the test unit and the control box. Plug PL-203 will be inserted in the test unit, and Plug PL-237 on the control box. Failure of the control box to function properly in these tests would indicate trouble in the interconnecting Cordage CO-220.

i. The radio control box and Cordage CO-220 with plugs can be checked with a continuity tester equivalent to Test Set I-56-A. This test set can be used to

determine the presence of open circuits, short circuits, poor grounding, improper voltages and other similar defects.

36. TEST PROCEDURE FOR MOUNTING FT-295-B.—The mounting FT-295-B, can also be tested with Test Set I-56-A or an equivalent continuity tester for the presence of open circuits, short circuits, poor grounding, improper voltage and other similar defects.

37. TEST PROCEDURE FOR BATTERIES BA-37 AND BA-38.—

a. Use Test Equipment IE-17-B for this test, but be sure that the external heavy duty batteries are disconnected. The radio set chassis with both crystals in place is mounted in the test case, connected to the test unit and then placed in the test stand. The "Press-To-Talk" switch must be in transmit position. The "MASTER SWITCH" of the test unit should be "OFF." Then place batteries BA-37 and BA-38 in the compartment in the test unit. Close and secure the compartment cover. See Fig. 14. "MODULATE TESTER" switch must be "OFF."

b. Place the "MASTER SWITCH" on test unit in "BA-37, 0-3 V. D.C." position and observe the meter reading. Normal readings will be between 1.35 and 1.5 volts. If the voltage is less than 1.25 volts, the battery should be discarded and replaced with a new one.

c. Place the "MASTER SWITCH" on test unit in "BA-38, 0-150 V. D.C." position and observe the meter reading. *Be sure the set is in transmit position.* The normal meter readings will be between 75 to 103.5 volts. If the voltage is below 70 volts, the battery should be discarded and replaced with a new one.

d. *When it becomes necessary to discard Battery BA-37 or Battery BA-38 because of low voltage, both batteries in the radio set should be replaced at the same time.* Batteries which are near the lower voltage limit may be used but they will reduce the overall performance of the radio set.

APPENDIX

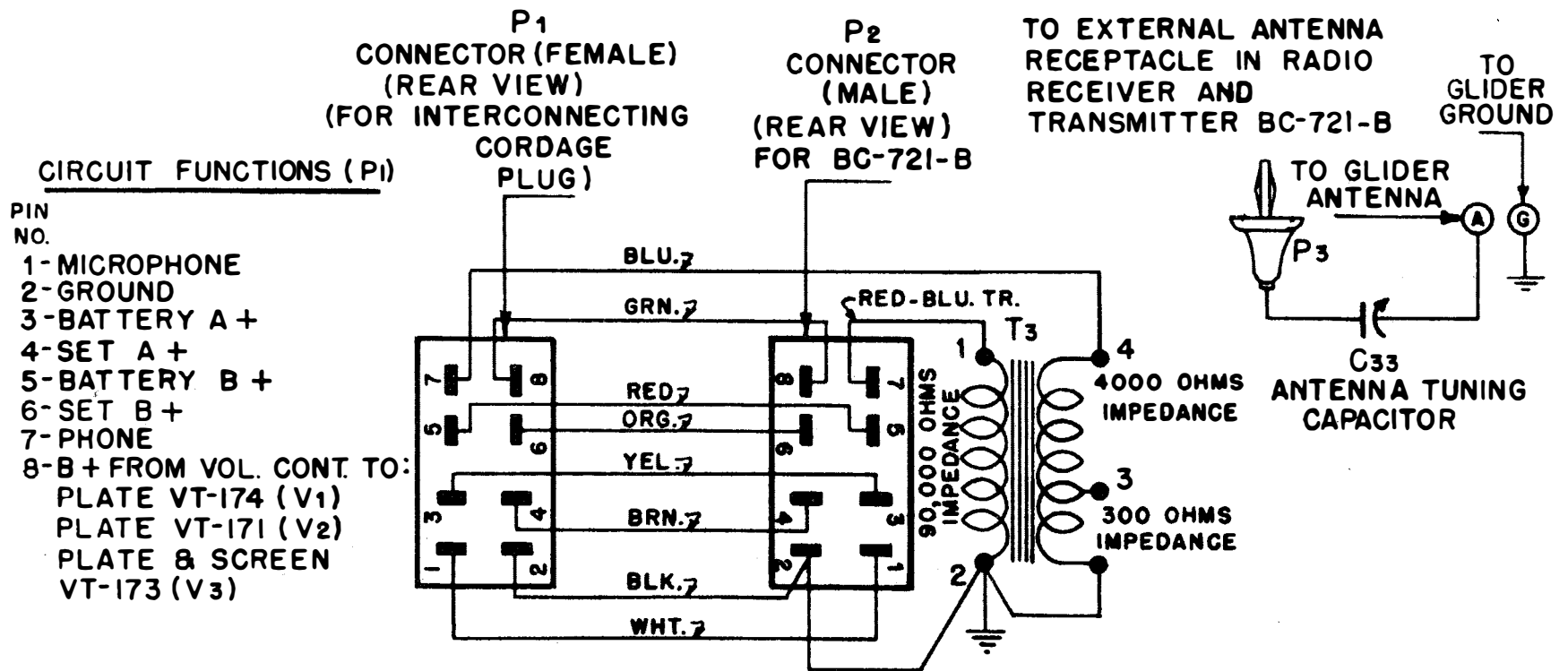

FIG. 17. MOUNTING FT-295-B, SCHEMATIC DIAGRAM

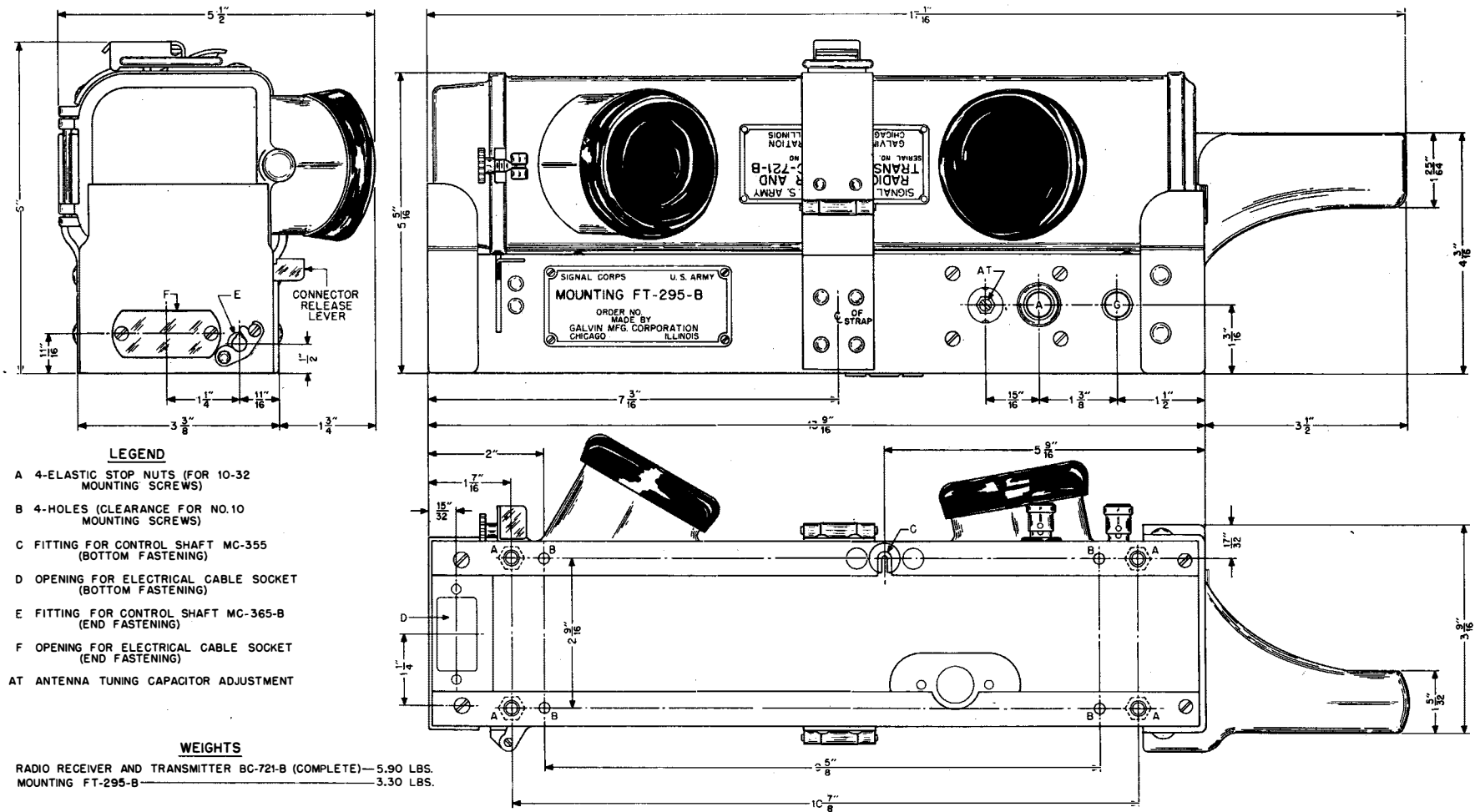

FIG. 19. RADIO RECEIVER AND TRANSMITTER BC-721-B ON MOUNTING FT-295-B, OUTLINE DIMENSIONAL DETAIL

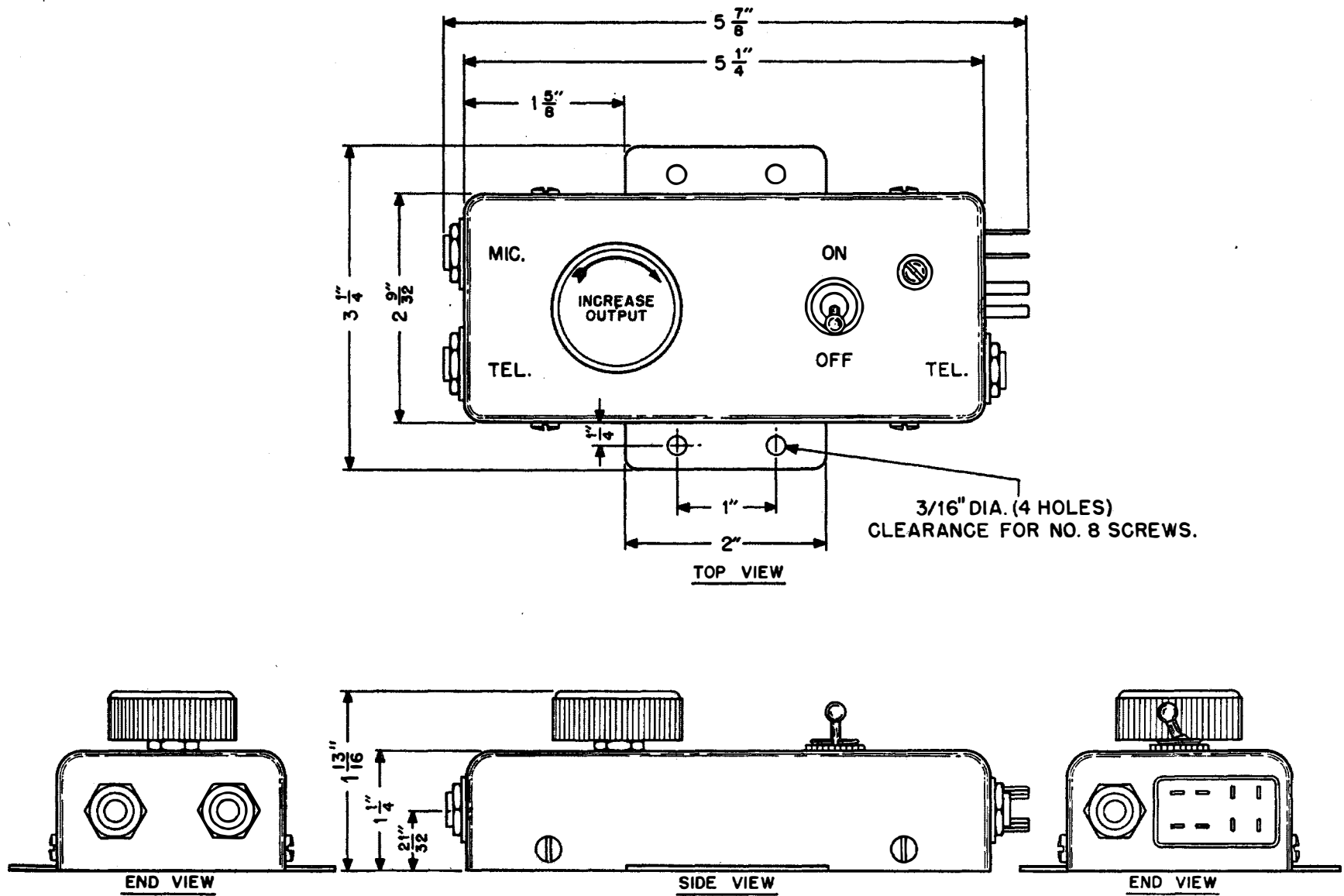

FIG. 20. RADIO CONTROL BOX BC-722-B, OUTLINE DIMENSIONAL DETAIL

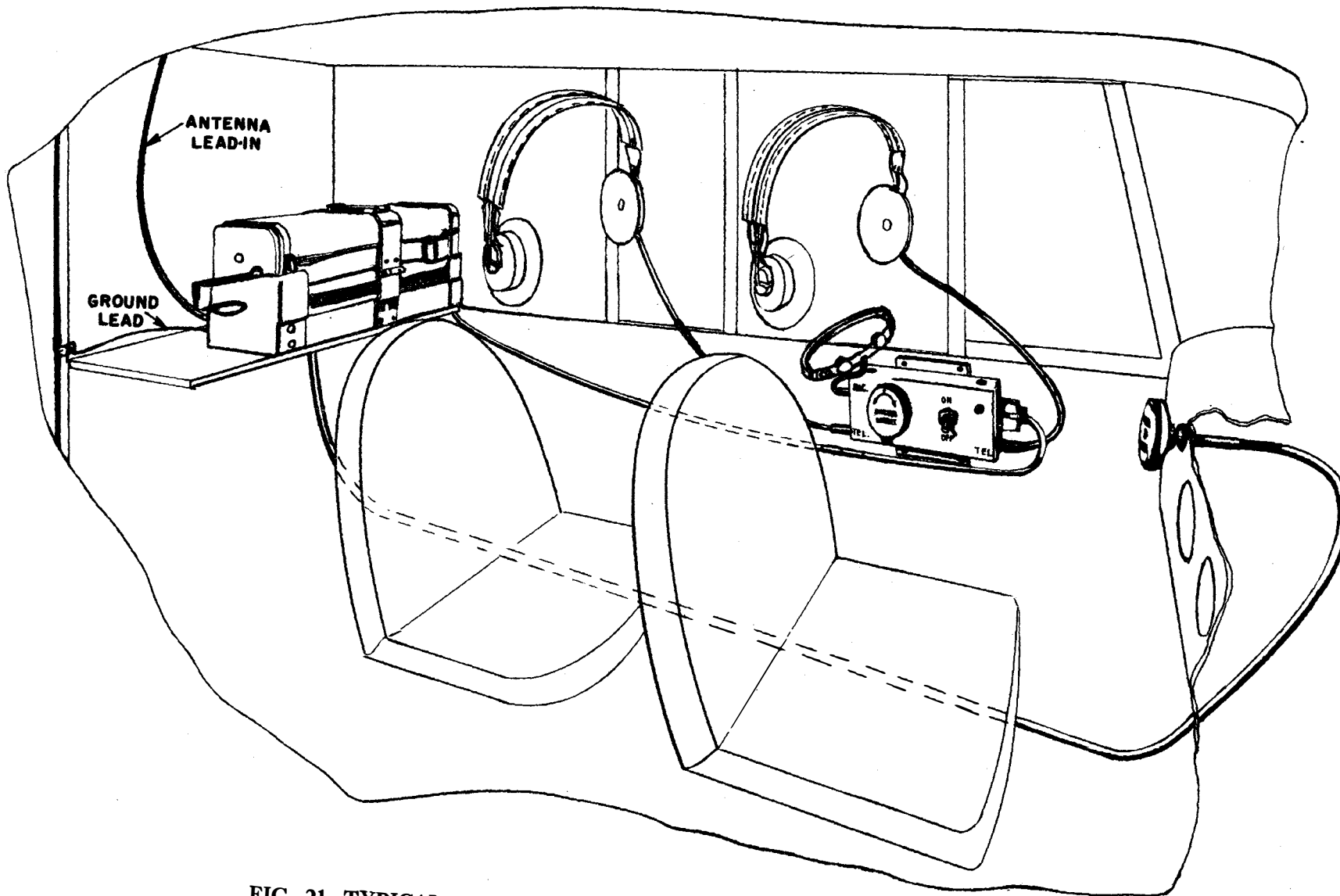
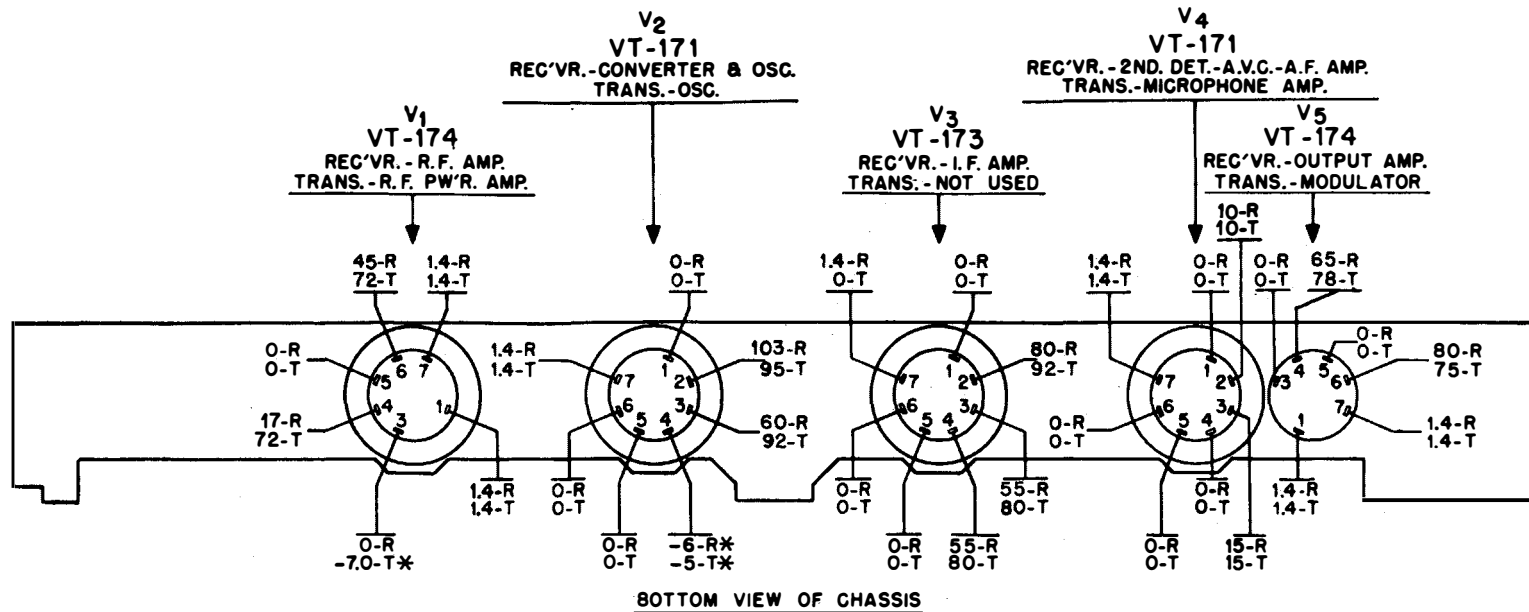

FIG. 21. TYPICAL INSTALLATION OF RADIO SET SCR-585-B, IN GLIDER



NOTE:- VOLTAGES WITH SUFFIX 'R' MEASURED IN RECEIVE POSITION.
 VOLTAGES WITH SUFFIX 'T' MEASURED IN TRANSMIT POSITION.

BIAS VOLTAGES MEASURED ON 30 VOLT RANGE OF VOLT-OHMETER
 UNIT OF 'SIGNAL CORPS TEST SET I-56-A'. ALL OTHER VOLTAGES
 MEASURED ON 300 VOLT RANGE.

'A' BATTERY VOLTAGE 1.4 V.

'B' BATTERY VOLTAGE (NEW BATTERY)- RECEIVE - 103 V.
 TRANSMIT - 95 V.

* VALUE MAY VARY CONSIDERABLY.

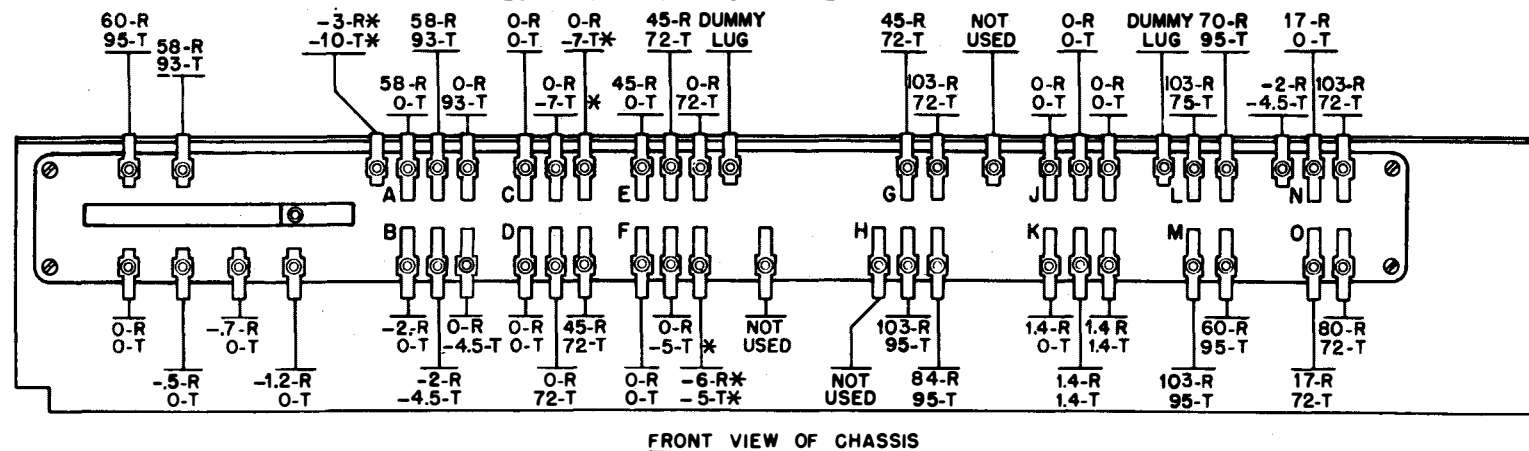
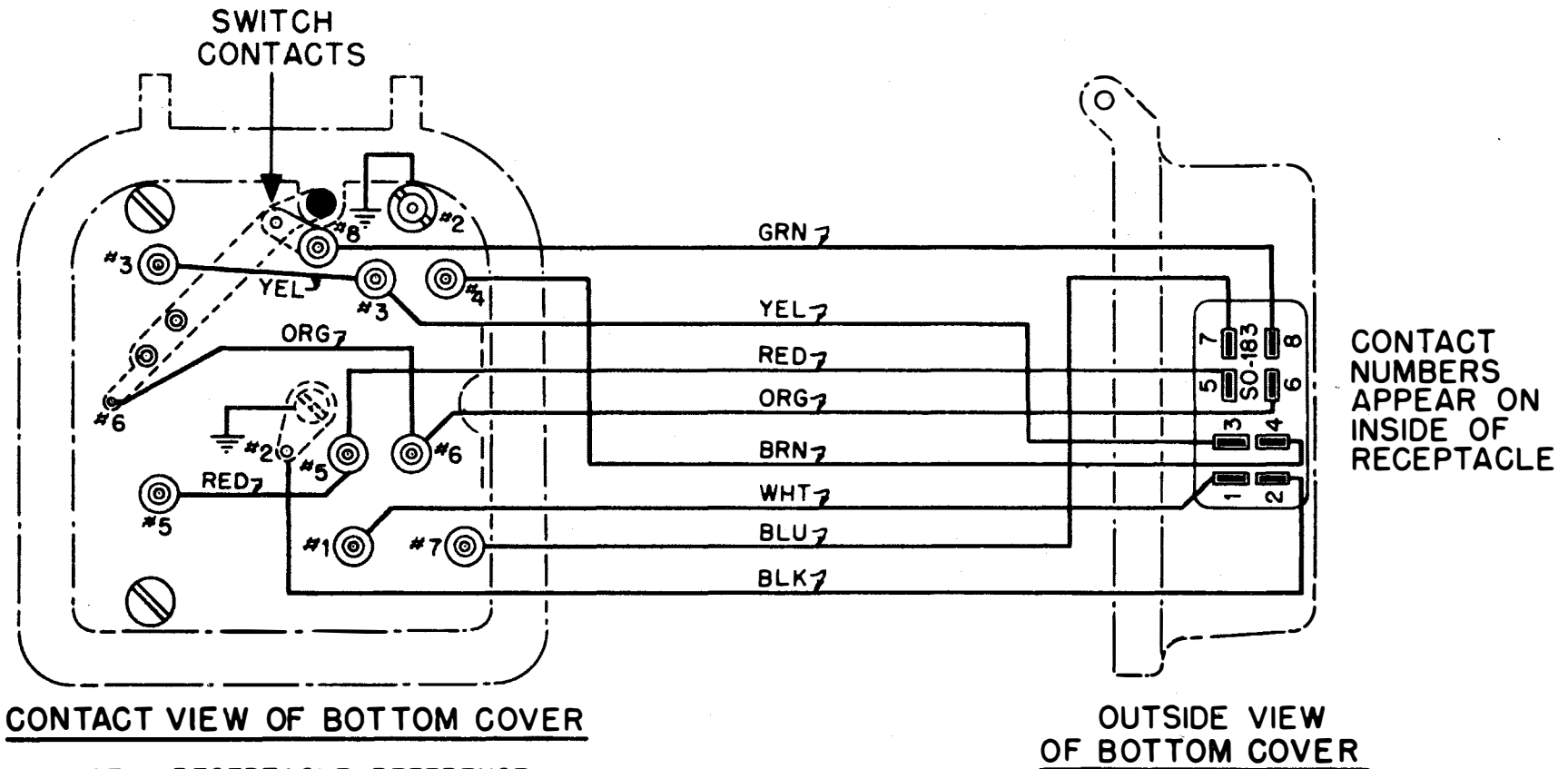

FIG. 22. RADIO RECEIVER AND TRANSMITTER BC-721-B, TUBE SOCKET AND TERMINAL VOLTAGE DIAGRAM



NOTE:- RECEPTACLE REFERENCE NUMBERS ADJACENT TO THE CONTACTS DO NOT APPEAR ON THE BOTTOM COVER PLATE

FIG. 23. RADIO RECEIVER AND TRANSMITTER BC-721-B, BOTTOM COVER WIRING DIAGRAM

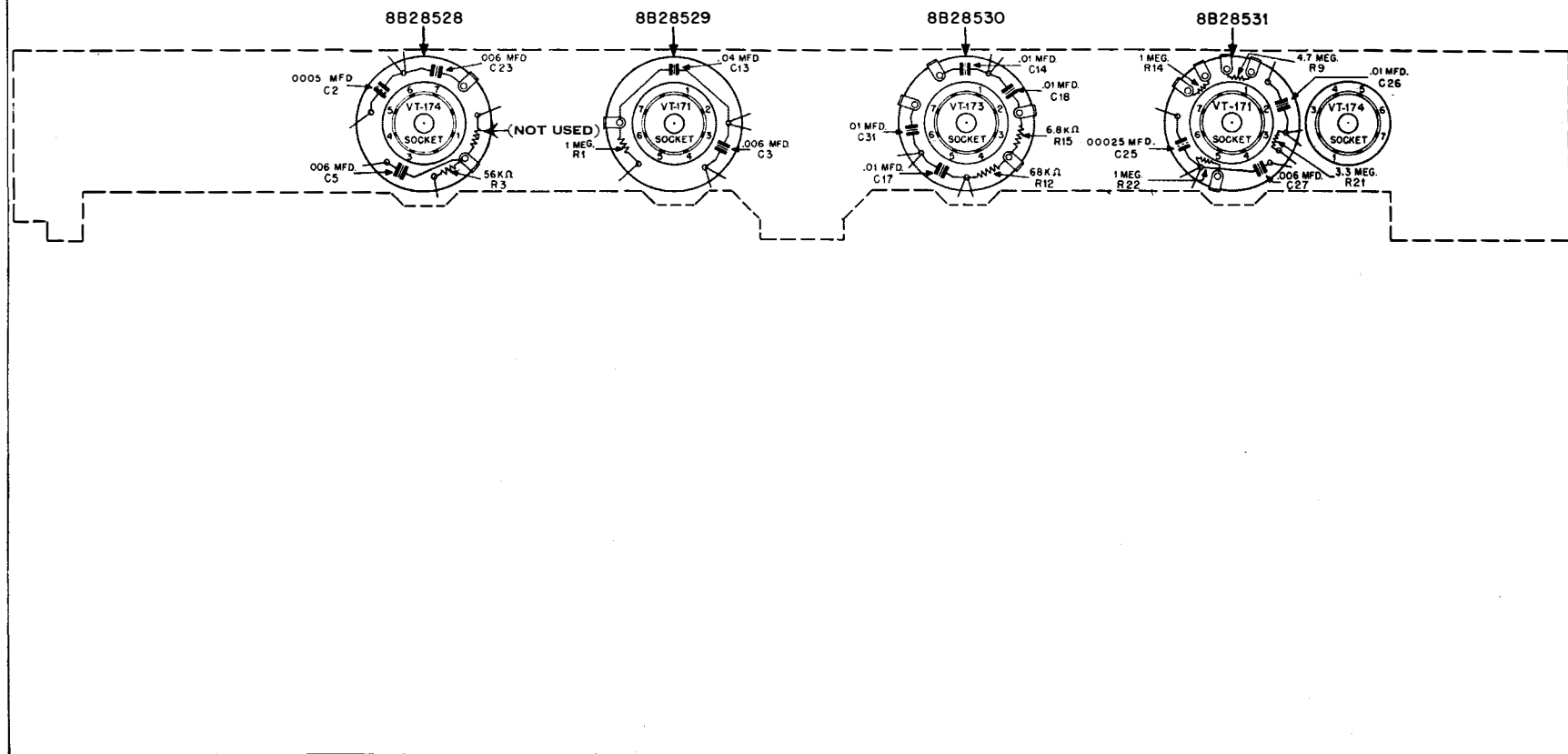

FIG. 24. RADIO RECEIVER AND TRANSMITTER BC-721-B, RESISTOR-CAPACITOR CUPS, SCHEMATIC DIAGRAM

38. RADIO RECEIVER AND TRANSMITTER BC-721-B—TABLE OF REPLACEABLE PARTS

Ref. No.	Signal Corps Stock No.	Name of Part	Description	Function	Contractor's Part and Draw'g No.	Mfg. †	Mfg. Type No.
C ₁		Capacitor	Fixed, paper; .006 μ f, \pm 10%, 100 w-v	Voltage blocking, V ₁	8A28544	3	
C ₂		Capacitor	Fixed, paper; .0005 μ f, \pm 20%, 100 w-v	Screen grid by-pass, V ₁	Part of 8B28528	3	
C ₃		Capacitor	Fixed, paper; .006 μ f, \pm 20%, 100 w-v	Plate by-pass, V ₁	Part of 8B28529	3	
C ₄		Capacitor	Fixed, ceramic; 7 μ μ f, \pm 5%	Grid neutralizing, V ₂	21A28815	6	#D
C ₅		Capacitor	Fixed, paper; .006 μ f, \pm 20%, 100 w-v	Grid bias by-pass, V ₂	Part of 8B28528	3	
C ₆		Capacitor	Fixed, mica; 25 μ μ f nominal (on same bracket as C ₇)	Oscillator feed-back	Part of 20A27459	7	
C ₇		Capacitor	Variable, mica; 18-160 μ μ f (On same bracket as C ₆)	Receiver antenna tuning	Part of 20A27459	7	
C ₈		Capacitor	Fixed, paper; .01 μ f, \pm 10%, 100 w-v	Filament by-pass, V ₁	8A28550	3	
C ₉		Capacitor	Fixed, ceramic; 25 μ μ f, \pm 10%	Coupling, V ₂ to V ₁ (transmitting)	21A28816	6	#D
C ₁₀		Capacitor	Fixed, ceramic; 15 μ μ f, \pm 20%	Coupling, V ₁ to V ₂ (receiving)	21A28817	6	#D
C ₁₁		Capacitor	Fixed, paper; .1 μ f, \pm 20%, 100 w-v	Screen grid by-pass	8A29846	3	
C ₁₂		Capacitor	Variable, air; 7-140 μ μ f	Tuning, L ₂	19A25990	28	
C ₁₃		Capacitor	Fixed, paper; .04 μ f, \pm 20%, 100 w-v	A.V.C. filter	Part of 8B28529	3	
C ₁₄		Capacitor	Fixed, paper; .01 μ f, \pm 20%, 100 w-v	Grid bias by-pass, V ₃	Part of 8B28530	3	
C ₁₅		Capacitor	Variable, mica; 58 μ μ f nominal. (On same base as C ₁₆)	Tuning, T ₁ primary	Part of 20A27340	7	
C ₁₆		Capacitor	Variable, mica; 58 μ μ f nominal. (On same base as C ₁₅)	Tuning, T ₁ secondary	Part of 20A27340	7	

†Numeral indicates manufacturer. See page 51 for manufacturer's name and address.

RADIO RECEIVER AND TRANSMITTER BC-721-B—TABLE OF REPLACEABLE PARTS—(Continued)

<i>Ref. No.</i>	<i>Signal Corps Stock No.</i>	<i>Name of Part</i>	<i>Description</i>	<i>Function</i>	<i>Contractor's Part and Draw'g No.</i>	<i>Mfg. †</i>	<i>Mfg. Type No.</i>
C 17		Capacitor	Fixed, paper; .01 μ f, $\pm 20\%$, 100 w-v	Grid bias by-pass, V ₃	Part of 8B28530	3	
C 18		Capacitor	Fixed, paper; .01 μ f, $\pm 20\%$, 100 w-v	Plate by-pass, V ₃	Part of 8B28530	3	
C 19		Capacitor	Variable, mica; 28 μ μ f nominal. (On same base as C ₂₀ and C ₂₁)	Tuning, T ₂ secondary	Part of 20A28609	7	
C 20		Capacitor	Fixed, mica; 70 μ μ f nominal. (On same base as C ₁₉ and C ₂₁)	Detector by-pass	Part of 20A28609	7	
C 21		Capacitor	Fixed, mica; 70 μ μ f, nominal. (On same base as C ₁₉ and C ₂₀)	Detector by-pass	Part of 20A28609	7	
C 22		Capacitor	Fixed, paper; .006 μ f, $\pm 10\%$, 100 w-v	A-F amplifier coupling	8A28544	3	
C 23		Capacitor	Fixed, paper; .006 μ f, $\pm 20\%$, 100 w-v	Grid bias by-pass, V ₄	Part of 8B28528	3	
C 24		Capacitor	Fixed, paper; .02 μ f, $\pm 10\%$, 100 w-v	Voltage blocking, a-f output	8A30263	3	
C 25		Capacitor	Fixed, paper; .00025 μ f, $\pm 20\%$, 100 w-v	Plate by-pass, V ₄	Part of 8B28531	3	
C 26		Capacitor	Fixed, paper; .01 μ f, $\pm 20\%$, 100 w-v	Screen grid by-pass, V ₄	Part of 8B28531	3	
C 27		Capacitor	Fixed, paper; .006 μ f, $\pm 20\%$, 100 w-v	Coupling, V ₄ to V ₅	Part of 8B28531	3	
C 28		Capacitor	Fixed, paper; .001 μ f, $\pm 10\%$, 100 w-v	Plate by-pass, V ₅	8A28545	3	
C 29		Capacitor	Fixed, paper; .075 μ f, $\pm 20\%$, 100 w-v	Screen grid by-pass, V ₅	8A28546	3	
C 30		Capacitor	Fixed, paper; .13 μ f, $\pm 20\%$, 100 w-v	Plate by-pass, V ₅	Part of 8A36209	3	
C 31		Capacitor	Fixed, paper; .01 μ f, $\pm 20\%$, 100 w-v	Plate, by-pass, V ₂	Part of 8B28530	3	
C 32		Capacitor	Fixed, paper; .075 μ f, $\pm 20\%$, 100 w-v	Plate by-pass, V ₅	Part of 8A36209	3	

†Numeral indicates manufacturer. See page 51 for manufacturer's name and address.

RADIO RECEIVER AND TRANSMITTER BC-721-B—TABLE OF REPLACEABLE PARTS—(Continued)

<i>Ref. No.</i>	<i>Signal Corps Stock No.</i>	<i>Name of Part</i>	<i>Description</i>	<i>Function</i>	<i>Contractor's Part and Draw'g No.</i>	<i>Mfg. ‡</i>	<i>Mfg. Type No.</i>
C 33		Capacitor	Variable, air; 4-75 $\mu\mu\text{f}$	Antenna tuning	19A35911	28	
C 34		Capacitor	Fixed, paper; .01 μf , $\pm 10\%$, 100 w-v	A.V.C. Filter	8A28550	3	
L 1		Coil	Antenna; frequency 3995 kc. No. C-414-A	Antenna loading	24K36079 *(24B36077)	1	
		Coil	Antenna; frequency 4845 kc. No. C-416-A	Antenna loading	24K36679 *(24B36077)	1	
		Coil	Antenna; frequency 5500 kc. No. C-418-A	Antenna loading	24K36680 *(24B36077)	1	
L 2		Coil	Tank; frequency 3995 kc. No. C-415-A	R-F tank	24K36085 *(24B36083)	1	
		Coil	Tank, frequency 4845 kc. No. C-417-A	R-F tank	24K36811 *(24B36083)	1	
		Coil	Tank; frequency 5500 kc. No. C-419-A	R-F tank	24K36812 *(24B36083)	1	
L 3		Coil	R-F choke; .5 millihenry	Oscillator plate load, V ₂	24A28595	46	
L 4		Coil	Audio output reactor; 590-850 ohms d-c resistance	Output plate load	25A28551	29	
M 1		Crystal	Receiver crystal (Specify frequency).	Receiver stability control	48K28681 *(48B27212)	47	
M 2		Crystal	Transmitter crystal (Specify frequency).	Transmitter frequency control	48B27212	47	
M 3		Switch	Change-over switch; eight pole, double throw.	"Send-receive" switch	40B25825	20	
M 4		Microphone	Microphone and leads assembly; dynamic	Transmitting speech	1X31098 (No draw'g)	48	
M 5		Earphone	Earphone and leads assembly; dynamic	Receiving	1X31094 (No draw'g)	48	
M 6		Switch	Toggle, double pole, single throw.	Heater & plate pwr. switch	40A25820	22	

‡Numeral indicates manufacturer. See page 51 for manufacturer's name and address.

*Indicates contractor's drawing number on which part will be found.

RADIO RECEIVER AND TRANSMITTER BC-721-B—TABLE OF REPLACEABLE PARTS—(Continued)

<i>Ref. No.</i>	<i>Signal Corps Stock No.</i>	<i>Name of Part</i>	<i>Description</i>	<i>Function</i>	<i>Contractor's Part and Draw'g No.</i>	<i>Mfg. †</i>	<i>Mfg. Type No.</i>
M ₇		Battery	BA-38 (103.5 to 106.5 volts)	Plate power supply	48B25848		
M ₈		Battery	BA-37 (1½ volt).	Filament power supply	48B27576		
M ₉		Tube shield	Metal shield	VT-174 shield	26A27204	31	
M ₁₀		Tube shield	Metal shield	VT-171 shield	26A27204	31	
M ₁₁		Tube shield	Metal shield	VT-173 shield	26A27204	31	
M ₁₂		Antenna	4 section collapsible antenna assembly.	Radiator for transmitter; Antenna for receiver	1C28682	1	
		Capacitor-Resistor Cup (VT-174)	Contains C ₂ , C ₅ , C ₂₃ , and R ₃	Capacitor, resistor container	8B28528	3	
		Capacitor-Resistor Cup (VT-171)	Contains C ₃ , C ₁₃ , and R ₁ .	Capacitor, resistor container	8B28529	3	
		Capacitor-Resistor Cup (VT-173)	Contains, C ₁₄ , C ₁₇ , C ₁₈ , C ₃₁ , R ₁₂ and R ₁₅	Capacitor, resistor container	8B28530	3	
		Capacitor-Resistor Cup (VT-171)	Contains C ₂₅ , C ₂₆ , C ₂₇ , R ₉ , R ₁₄ , R ₂₁ and R ₂₂ .	Capacitor, resistor container	8B28531	3	
R ₁		Resistor	Fixed, carbon; 1 megohm, ±10%, ½ watt, not insulated.	Converter grid, V ₂	Part of 8B28529	3	
R ₂		Resistor	Fixed, carbon; 470,000 ohms, ±10%, ½ watt, insulated.	Grid bias, V ₃	6B6338	45	"MB ½" Ins.
R ₃		Resistor	Fixed, carbon; 56,000 ohms, ±10%, ½ watt, not insulated.	Oscillator grid bias, V ₂	Part of 8B28528	3	
R ₄		Resistor	Fixed, carbon; 47,000 ohms, ±10%, ½ watt, insulated.	Sensitivity control	6B6323	45	"MB ½" Ins.
R ₅		Resistor	Fixed, carbon; 15,000 ohms, ±10%, ½ watt, insulated.	Sensitivity control	6B6422	45	"MB ½" Ins.
R ₆		Resistor	Fixed, carbon; 470,000 ohms, ±10%, ½ watt, insulated.	Grid bias, V ₁	6B6338	45	"MB ½" Ins.

†Numeral indicates manufacturer. See page 51 for manufacturer's name and address.

RADIO RECEIVER AND TRANSMITTER BC-721-B—TABLE OF REPLACEABLE PARTS—(Continued)

<i>Ref. No.</i>	<i>Signal Corps Stock No.</i>	<i>Name of Part</i>	<i>Description</i>	<i>Function</i>	<i>Contractor's Part and Draw'g No.</i>	<i>Mfg. †</i>	<i>Mfg. Type No.</i>
R 7		Resistor	Fixed, carbon; 22,000 ohms, $\pm 10\%$, $\frac{1}{8}$ watt, insulated.	Sensitivity control	6B6370	45	"MB $\frac{1}{8}$ " Ins.
R 8		Resistor	Fixed, carbon; 1 megohm, $\pm 10\%$, $\frac{1}{8}$ watt, not insulated.	Load, T ₁ secondary	6B5564	15	997-A
R 9		Resistor	Fixed, carbon; 4.7 megohm, $\pm 10\%$, $\frac{1}{8}$ watt, not insulated.	A.V.C. filter	Part of 8B28531	3	
R 10		Resistor	Fixed, carbon; 22,000 ohms, $\pm 10\%$, $\frac{1}{8}$ watt, insulated.	Plate dropping, V ₁	6B6370	45	"MB $\frac{1}{8}$ " Ins.
R 11		Resistor	Fixed, carbon; 3,300 ohms, $\pm 10\%$, $\frac{1}{8}$ watt, insulated.	Plate dropping, V ₅	6B6379	45	"MB $\frac{1}{8}$ " Ins.
R 12		Resistor	Fixed, carbon; 68,000 ohms, $\pm 10\%$, $\frac{1}{8}$ watt, not insulated.	Screen grid dropping, V ₃	Part of 8B28530	3	
R 13		Resistor	Fixed, carbon, 220,000 ohms, $\pm 10\%$, $\frac{1}{8}$ watt, not insulated.	Detector filter, V ₄	6B5571	15	997-A
R 14		Resistor	Fixed, carbon; 1 megohm, $\pm 10\%$, $\frac{1}{8}$ watt, not insulated.	Detector load, V ₄	Part of 8B28531	3	
R 15		Resistor	Fixed, carbon; 6,800 ohms, $\pm 10\%$, $\frac{1}{8}$ watt, not insulated.	Plate dropping, V ₃	Part of 8B28530	3	
R 16		Resistor	Fixed, carbon; 33,000 ohms, $\pm 10\%$, $\frac{1}{8}$ watt, insulated.	Screen grid dropping, V ₅	6B6448	45	"MB $\frac{1}{8}$ " Ins.
R 17		Resistor	Fixed, carbon; 22,000 ohms, $\pm 10\%$, $\frac{1}{8}$ watt, insulated.	Screen grid dropping, V ₂	6B6370	45	"MB $\frac{1}{8}$ " Ins.
R 18		Resistor	Fixed, carbon; 100,000 ohms, $\pm 10\%$, $\frac{1}{8}$ watt, insulated.	Screen grid dropping, V ₁	6B6369	45	"MB $\frac{1}{8}$ " Ins.
R 19		Resistor	Fixed, carbon; 33,000 ohms, $\pm 10\%$, $\frac{1}{8}$ watt, insulated.	Oscillator grid bias, V ₂	6B6448	45	"MB $\frac{1}{8}$ " Ins.
R 20		Resistor	Fixed, carbon; 10 megohms, $\pm 10\%$, $\frac{1}{8}$ watt, insulated.	Grid bias, V ₄	6B5572	14	"EB" Ins.

†Numeral indicates manufacturer. See page 51 for manufacturer's name and address.

RADIO RECEIVER AND TRANSMITTER BC-721-B—TABLE OF REPLACEABLE PARTS—(Continued)

<i>Ref. No.</i>	<i>Signal Corps Stock No.</i>	<i>Name of Part</i>	<i>Description</i>	<i>Function</i>	<i>Contractor's Part and Draw'g No.</i>	<i>Mfg. †</i>	<i>Mfg. Type No.</i>
R 21		Resistor	Fixed, carbon; 3.3 megohms, $\pm 10\%$, $\frac{1}{3}$ watt, not insulated.	Screen grid dropping, V ₄	Part of 8B28531	3	
R 22		Resistor	Fixed, carbon; 1 megohm, $\pm 10\%$, $\frac{1}{5}$ watt, not insulated.	Plate load, V ₄	Part of 8B28531	3	
R 23		Resistor	Fixed, carbon; 3.3 megohms, $\pm 10\%$, $\frac{1}{3}$ watt, insulated.	Grid bias, V ₅	6B6364	45	"MB $\frac{1}{3}$ " Ins.
R 24		Resistor	Fixed, carbon; 3900 ohms, $\pm 10\%$, $\frac{1}{3}$ watt, insulated.	Screen grid decoupling, V ₅	6B5573	45	"MB $\frac{1}{3}$ " Ins.
R 25		Resistor	Fixed, carbon; 33,000 ohms, $\pm 10\%$, $\frac{1}{3}$ watt, insulated.	Sensitivity control	6B6448	45	"MB $\frac{1}{3}$ " Ins.
R 26		Resistor	Fixed, carbon; 4.7 megohms, $\pm 10\%$, $\frac{1}{3}$ watt, insulated.	A.V.C. filter	6B6391	14	"EB" Ins.
R 27		Resistor	Fixed, carbon; 330,000 ohms, $\pm 10\%$, $\frac{1}{3}$ watt, insulated.	Screen grid dropping, V ₄	6B6366	45	"MB $\frac{1}{3}$ " Ins.
R 29		Resistor	Fixed, carbon; 3.3 megohms, $\pm 10\%$, $\frac{1}{3}$ watt, insulated.	Overload resistor	6B6364	45	"MB $\frac{1}{3}$ " Ins.
R 30		Resistor	Fixed, carbon; 3.3 megohms, $\pm 10\%$, $\frac{1}{3}$ watt, insulated.	Decoupling resistor	6B6364	45	"MB $\frac{1}{3}$ " Ins.
R 31		Resistor	Fixed, carbon; 470,000 ohms, $\pm 10\%$, $\frac{1}{3}$ watt, insulated.	Damping, M ₄	6B6338	45	"MB $\frac{1}{3}$ " Ins.
T 1		Transformer, I-F Input ‡	I-F input coil & shield assembly mounted in can.	Coupling, V ₂ to V ₃	1B28670	1	
T 2		Transformer, I-F Output	I-F output coil and shield assembly, mounted in can.	Coupling, V ₃ and V ₄	1B28668	1	
		Arm, Switch Lever (long)	Metal; 2" long, $\frac{9}{16}$ " wide.	Part of "press-to-talk" switch lever assembly	45B27215	1	
		Arm, Switch Lever (short)	Metal, 1 $\frac{1}{8}$ " long, $\frac{9}{16}$ " wide.	Part of "press-to-talk" switch lever assembly.	45A25998	1	

†Numeral indicates manufacturer. See page 51 for manufacturer's name and address.

RADIO RECEIVER AND TRANSMITTER BC-721-B—TABLE OF REPLACEABLE PARTS—(Continued)

<i>Ref. No.</i>	<i>Signal Corps Stock No.</i>	<i>Name of Part</i>	<i>Description</i>	<i>Function</i>	<i>Contractor's Part and Draw'g No.</i>	<i>Mfg. †</i>	<i>Mfg. Type No.</i>
		Assembly, Antenna Cap and Chain	Aluminum cap; $\frac{15}{16}$ " diameter, $3\frac{3}{8}$ " high, beaded chain 4" long.	Cover for antenna	1X28690 (No draw'g)	1	
		Assembly, Bracket and Grommet	Aluminum; $\frac{3}{4}$ "x $\frac{1}{2}$ ", has $\frac{5}{16}$ " hole with rubber grommet.	Holds V ₄ and V ₅ secure in socket.	1X30139 (No draw'g)	1	
		Assembly, Bottom Cover	Metal; $3\frac{3}{16}$ "x $3\frac{3}{8}$ ". Complete with connect-or plate and plug receptacle.	Bottom cover of housing	1X35967 (No draw'g)	1	
		Assembly, End Plate	Bakelite; $3\frac{1}{16}$ "x $1\frac{1}{2}$ " complete with terminals and contacts.	End plate of chassis	1X28667 (No draw'g)	1	
		Assembly, Filler and Clips	Fibre; $1\frac{1}{4}$ " wide, $11\frac{1}{2}$ " long. Clip riveted on each end	Used to fill space between Battery BA-38 & housing	1X29050 (No draw'g)	1	
		Assembly, Spade Bolt & Cover Nut	$\frac{7}{8}$ " spade bolt with $\frac{5}{8}$ " diameter knurled edge nut.	Holds bottom cover shut	1X29661 (No draw'g)	1	
		Assembly, Strap	Olive drab web strap; $1\frac{1}{4}$ " wide, 30" long.	Carrying strap	1X28691 (No draw'g)	1	
		Assembly, Top Cover	Aluminum; $3\frac{1}{4}$ "x $3\frac{3}{8}$ " complete with battery spacer and springs, antenna insulator, moisture seal and strap hanger.	Top cover of housing	1X28688 (No draw'g)	1	
		Ball End, Antenna	Marblette ball; $\frac{1}{4}$ " diameter, olive drab finish.	On tip of antenna to aid in pulling antenna out.	43A38501	53	
		Bezel, Data Plate	Aluminum frame, $2\frac{1}{16}$ "x $1\frac{7}{8}$ "	Frame for data plate	13A28571	1	
		Bracket, Switch Stop	Metal; $\frac{3}{8}$ "x $\frac{5}{8}$ ", with a .144" diameter hole.	Part of "press-to-talk" switch. Lever stop.	7A31332	1	
		Bracket, Tube Retainer	Aluminum, $\frac{3}{4}$ "x $\frac{1}{2}$ ". Has $\frac{5}{16}$ " hole.	Holds tube shield for V ₁ , V ₂ and V ₃ secure	7A25988	54	
		Cap, Phone and Mike	Molded bakelite; $2\frac{5}{8}$ " diameter.	Cap for mouthpiece and earpiece	67B25832	55	
		Clamp, Capacitor	Brass; semi-circular, $\frac{1}{8}$ " radii	Holds capacitor C ₃₀ secure.	42A28454	23	
		Clamp, Crystal	Phosphor bronze; $\frac{5}{8}$ " wide, "L" shaped.	Holds crystals secure	42A28543	1	

†Numeral indicates manufacturer. See page 51 for manufacturer's name and address.

RADIO RECEIVER AND TRANSMITTER BC-721-B—TABLE OF REPLACEABLE PARTS—(Continued)

<i>Ref. No.</i>	<i>Signal Corps Stock No.</i>	<i>Name of Part</i>	<i>Description</i>	<i>Function</i>	<i>Contractor's Part and Draw'g No.</i>	<i>Mfg. †</i>	<i>Mfg. Type No.</i>
		Cover, Data Plate	Clear vinylite; 1 $\frac{5}{8}$ "x1 $\frac{3}{16}$ ".	Transparent cover for data plate	61A28456	56	
		Cover, R-F Choke	Bakelite; 1" long, $\frac{1}{2}$ " outside diameter.	Cover for r-f choke L ₃	67A30885	57	
		Cover, Socket	Metal; 1 $\frac{1}{2}$ " long, $\frac{3}{4}$ " wide, has beaded chain 4" long attached.	Cover for Socket SO-183	15A35668	1	
		Cover, Switch	Acetate celluloid; 1 $\frac{1}{8}$ "x10 $\frac{3}{4}$ "	Cover for change-over switch assembly.	61B28450	56	
		Cover, Switch Mechanism	Molded rubber; 1 $\frac{7}{8}$ "x4".	Cover for "press-to-talk" switch assembly.	37C27218	59	
		Frame, Cover Clamping	Aluminum frame 1 $\frac{7}{8}$ "x4", has 6 .156" diameter holes for mounting.	Frame for "press-to-talk" switch cover.	42B25987	1	
		Fulcrum, Hinge	Alcoa metal, one .156" hole for mounting, one .067 hole for hinge pin.	Part of "press-to-talk" switch assembly.	45A27219	1	
		Guide, Antenna	Molded bakelite; 7 $\frac{5}{16}$ " long, .282" diameter groove.	Guide in which antenna slides	67B36390	1	
		Housing	Housing only; 11 $\frac{1}{2}$ "x3"x3 $\frac{1}{4}$ ".	Housing for unit	15D35920	1	
		Link, Sliding Hinge	Metal; 1 $\frac{1}{2}$ "x $\frac{7}{16}$ ", slotted, hole at end for hinge pin.	Part of "press-to-talk" switch assembly	45B27221	1	
		Nut, Chamfered	Brass; nickel plated; $\frac{5}{16}$ "-32x $\frac{7}{16}$ "	Tank capacitor mounting	2A30408	1	
		Pin, Groove	Metal; $\frac{1}{2}$ " long, .093" diameter.	Hinge pin for mounting spade bolt and nut.	47A28460	63	
		Pin, Hinge	Metal; $\frac{1}{2}$ " long, .125" diameter, 4-36 thread on one end.	Part of "press-to-talk" switch; holds long and short levers together.	47A25997	66	
		Pin, Hinge	.672" long x .062" diameter.	Part of "press-to-talk" switch assembly.	47A25999	68	
		Plate, Data	Vinylite plate; 1 $\frac{5}{8}$ "x1 $\frac{3}{16}$ ".	Frequency, channel and battery date information plate.	13A28455	56	

†Numeral indicates manufacturer. See page 51 for manufacturer's name and address.

RADIO RECEIVER AND TRANSMITTER BC-721-B—TABLE OF REPLACEABLE PARTS—(Continued)

<i>Ref. No.</i>	<i>Signal Corps Stock No.</i>	<i>Name of Part</i>	<i>Description</i>	<i>Function</i>	<i>Contractor's Part and Draw'g No.</i>	<i>Mfg. †</i>	<i>Mfg. Type No.</i>
		Plate, Antenna Cover Slider	Metal; 1½" x 1¾", scored on one end for finger grip. With rubber seal.	Weatherproofing for external antenna receptacle.	64A35536	1	
		Plug, Jumper	Molded bakelite over wire jumper ⅝" x ¼".	Jumper for plate meter terminals when meter is not used.	28A28535	58	
		Rod, Housing & Strap Supp't (long)	2" long, ⅝" diameter; threaded at one end.	Bottom cover hinge rod and strap support.	46K27220 *(46A25849)	66	
		Rod, Housing & Strap Supp't (short)	1¾" long, ⅜" diameter; threaded at one end.	Top cover hinge rod and strap hanger support	46A25849	66	
		Seal, Moisture	Rubber, ⅝" diameter, ¼" hole.	Weatherproofing at antenna through top cover	37A27308	32	
		Seal, Rubber Ring	Sponge rubber ring; ⅛", 3⅜" x 3¼"	Top and bottom cover rubber seal	37A25986	59	
		Socket, Cable Connector	8 contact (female) receptacle; No. SO-183	Bottom cover receptacle.	9K36227 *(9A36226)	49	
		Socket, Crystal	2 crystal receptacle	Socket for 2 crystals	9A25981	23	
		Spring, Coil Retainer	Phosphor bronze; ⅜" x ¼", has .127" diameter hole for mounting.	Tank coil retainer spring	41A25995	23	
		Spring, Cushion	Phosphor bronze; ⅞" x ⅜" spring.	Part of "press-to-talk" switch assembly	41A28452	23	
		Spring, Switch Lever	Stainless steel spring	Lever return spring, part of "press-to-talk" switch assembly.	41A27203	70	
		Tube Socket	7 prong miniature	VT-171, and VT-173 tube socket.	9A6794	23	
		Tube Socket	6 prong miniature	VT-174 tube socket	9K6796 *(9A6794)	23	

†Numeral indicates manufacturer. See page 51 for manufacturer's name and address.

*Indicates contractor's drawing number on which part will be found.

RADIO CONTROL BOX BC-722-B—TABLE OF REPLACEABLE PARTS

<i>Ref. No.</i>	<i>Signal Corps Stock No.</i>	<i>Name of Part</i>	<i>Description</i>	<i>Function</i>	<i>Contractor's Part and Draw'g No.</i>	<i>Mfg. †</i>	<i>Mfg. Type No.</i>
J ₁		Jack, Microphone	Open circuit type.	Microphone jack.	40A30454	52	
J ₂		Jack, Telephone	Closed circuit type	Telephone jack	40A35529	52	
J ₃		Jack, Telephone	Closed circuit type	Telephone jack	40A35529	52	
P ₄		Assembly Connector and Bracket	8 contact (male) plug No. SO-217	Cordage Connector	1X35965 (No draw'g)	1	
R ₂₈		Potentiometer, Volume Control	500,000 ohms.	Volume Control	18A36208	14	
R ₃₂		Resistor	Fixed, carbon; 22,000 ohms, ±10%, 1/3 watt, insulated.	Voltage divider	6B6370	45	"MB 1/3" Ins.
R ₃₃		Resistor	Fixed, carbon; 33,000 ohms, ±10%, 1/3 watt, insulated.	Voltage divider	6B6448	45	"MB 1/3" Ins.
SW ₁		Switch	Toggle; double pole, single throw.	"A" and "B" battery power off-on.	40A36441	22	
T ₄		Transformer, Microphone	Turns ratio 8.8 to 1	Microphone transformer	25B35957	11	
		Cover, Control Box, Bottom	Steel, black nickel, 3 1/4" x 5 1/4" x 3/16"	Bottom cover for Control Box	15B35578	41	
		Housing, Control Box	Steel, painted. 2 9/32" x 5 1/4" x 1 1/4"	Housing for parts	15B31913	1	
		Knob, Control	Knob No. MC-168.	Volume Control	36A35586		
		Wiper, Friction	Phosphor bronze spreader No. MM6	Holds Volume Control in any set position.	39A35952		

†Numeral indicates manufacturer. See page 51 for manufacturer's name and address.

MOUNTING BASE FT-295-B—TABLE OF REPLACEABLE PARTS

Ref. No.	Signal Corps Stock No.	Name of Part	Description	Function	Contractor's Part and Draw'g No.	Mfg. †	Mfg. Type No.
C ₃₃		Capacitor	Variable air; 4 to 75 μ f.	Antenna tuning	19A35911	28	
P ₁		Connector	8 contact (female) receptacle	Chassis mounting receptacle	9A36226	49	
P ₂		Connector	8 contact (male) plug	Chassis mounting plug	28A36203	49	
P ₃		Assembly, Antenna Plug	Banana plug in self-centering mount.	Antenna plug	1X35975 (No draw'g)	1	
T ₃		Transformer, Output	Matching transformer for 8000 and 600 ohm headsets.	Output matching transformer	25B35917	11	
		Assembly, Strap and Clasp	$3\frac{1}{16}$ "x $1\frac{1}{4}$ " hinge strap with steel spring clip $1\frac{1}{4}$ "x $2\frac{3}{4}$ " and clasp.	Holds BC-721-B secure to mounting base.	1X36027 (No draw'g)	1	
		Assembly, Strap and Clip	$3\frac{1}{16}$ "x $1\frac{1}{4}$ " hinge strap with steel spring clip $2\frac{3}{4}$ "x $1\frac{1}{4}$ " and latch.	Holds BC-721-B secure to mounting base.	1X36026 (No draw'g)	1	
		Assembly, Switch Actuating	3 arms with rollers on one arm to press switch.	Switch actuator for control shaft MC-365-B	1X35977 (No draw'g)	1	
		Base, Mounting	Metal; $13\frac{3}{8}$ "x $3\frac{1}{4}$ "x2"	Chassis	27D35594	1	
		Bracket, Chassis End	Alcoa No. 13; $3\frac{5}{16}$ "x $2\frac{1}{64}$ "x $1\frac{5}{32}$ "	Alignment	7C35632	1	
		Gasket, Antenna Insulator	Felpak; mounting centers 1.156".	Gasket for antenna insulator	32A35912	50	
		Guard, Antenna	Metal; 4" wide, $4\frac{1}{2}$ " long.	Antenna cap protector.	26C35599	41	
		Insulator, Capacitor	Molded bakelite; $2\frac{3}{16}$ "x $1\frac{1}{16}$ "x $1\frac{1}{16}$ "	Supports antenna post and antenna tuning capacitor.	14A35555		
		Lever, Release	Metal; $1\frac{1}{8}$ " wide, $2\frac{3}{8}$ " long.	Aid in removing BC-721-B from mounting base.	45A31904	1	
		Shaft, Actuator	Metal; .248" diameter 3.245" long.	Shaft for switch actuator.	47A35571	51	

†Numeral indicates manufacturer. See page 51 for manufacturer's name and address.

MOUNTING BASE FT-295-B—TABLE OF REPLACEABLE PARTS—(Continued)

<i>Ref. No.</i>	<i>Signal Corps Stock No.</i>	<i>Name of Part</i>	<i>Description</i>	<i>Function</i>	<i>Contractor's Part and Draw'g No.</i>	<i>Mfg. †</i>	<i>Mfg. Type No.</i>
		Terminal Binding Post	Metal post; 1/2" diameter, 3/4" long.	External ground terminal	29A35913	51	
		Terminal Binding Post	Metal post; 1/2" diameter, 3/4" long.	External antenna terminal	29K35914 *(29A35913)	51	

CONTROL SHAFTS MC-355 AND MC-365-B—TABLE OF REPLACEABLE PARTS

	2Z3226-355	Control Shaft	"Pull-to-talk" Control Shaft MC-355, for bottom fastening	Used to actuate Transmitter SCR-585-B.			
	2Z3226-365B	Control Shaft	"Pull-to-talk" Control Shaft MC-365-B, for end fastening.	Used to actuate Transmitter SCR-585-B.			
		Knob	"Pull-to-talk" knob with Allen set screw.	Part of MC-355 and MC-365-B.			
		Nut, Mounting	Brass, nickel plated, 3/4"x16, 3/16" thick.	For fastening control shafts to support.			
		Washer, Lock	Steel, nickel plated, 3/4" I.D.	For locking control shafts to support.			

RADIO RECEIVER AND TRANSMITTER BC-721-B—MISCELLANEOUS—TABLE OF REPLACEABLE PARTS

	3E2220	Cordage	Cordage CO-220, Seven conductor, each A.W.G. No. 20, color coded red, brown, orange, green with white tracer, yellow, green and white. White and green leads individually shielded.	Used to connect BC-722-B to FT-295-B.			
	2Z7226-237	Plug	8 contact (female) plug No. PL-237	Cordage connector	9A38320	49	
	2Z7226-203	Plug	8 contact (male) plug No. PL-203	Cordage connector	28A38319	49	

†Numeral indicates manufacturer. See page 51 for manufacturer's name and address.

*Indicates contractor's drawing number on which part will be found.

RADIO SET SCR-585-B

KEY TO SUPPLIERS

<i>Key No.</i>	<i>Name</i>	<i>Street Address</i>	<i>City and State</i>
1	Galvin Mfg. Corporation.....	4545 W. Augusta Blvd.....	Chicago, Illinois
3	J. E. Fast Co.....	3123 N. Crawford Ave.....	Chicago, Illinois
6	Centralab.....	900 East Keefe Ave.....	Milwaukee, Wisconsin
7	Underwood Electric Co.....	3120 West Grand Ave.....	Chicago, Illinois
11	Standard Transformer Corp.....	1500 N. Halsted St.....	Chicago, Illinois
14	Allen Bradley Co.....		Milwaukee, Wisconsin
15	Carborundum Corporation.....	Globar Division.....	Niagara Falls, New York
22	Cutler-Hammer Company.....		Milwaukee, Wisconsin
23	Cinch Mfg. Company.....	2339 W. Van Buren St.....	Chicago, Illinois
28	Radio Condenser Co.....		Camden, New Jersey
29	Chicago Transformer Corp.....	3501 Addison Street.....	Chicago, Illinois
31	Erie Can Company.....	816 W. Erie St.....	Chicago, Illinois
32	Atlantic India Rubber Co.....	1453 W. Van Buren St.....	Chicago, Illinois
41	Northern Metal Products.....	2911 W. Carroll Ave.....	Chicago, Illinois
45	Stackpole Carbon Co.....	Elk County.....	St. Marys, Penna.
46	Ross Mfg. Company.....	2241 S. Indiana Ave.....	Chicago, Illinois
47	Gentlemen Products.....	1708 Cummings.....	Omaha, Nebraska
48	Permoflux Corp.....	4916-22 W. Grand Ave.....	Chicago, Illinois
49	Howard B. Jones & Co.....	2300 Wabansia Ave.....	Chicago, Illinois
50	Felt Products Co.....	1508 Carroll Ave.....	Chicago, Illinois
51	American Radio Hardware Co.....	476 Broadway.....	New York, New York
52	Utah Radio Products.....	820 Orleans.....	Chicago, Illinois
53	Keolyn Plastics.....	2731 N. Crawford.....	Chicago, Illinois
54	Poray, Inc.....	3403 West Grand Ave.....	Chicago, Illinois
55	Plano Molding.....		Plano, Illinois
56	Cruver Mfg. Company.....	2456 W. Jackson Blvd.....	Chicago, Illinois
57	National Fabricating.....	2650 West Belden.....	Chicago, Illinois
58	American Molded Products.....	1753 N. Honore St.....	Chicago, Illinois
59	B. F. Goodrich Company.....	1247 S. High Street.....	Akron, Ohio
63	Groove Pin Corp.....	2017 Kerrigan Ave.....	Union City, New Jersey
66	Merkle Metal Products.....	213 N. Morgan Street.....	Chicago, Illinois
68	Lincoln Mfg. Co.....	2617 West Fletcher.....	Chicago, Illinois
70	Automatic Spring Coil.....	4045 West Thorndale.....	Chicago, Illinois

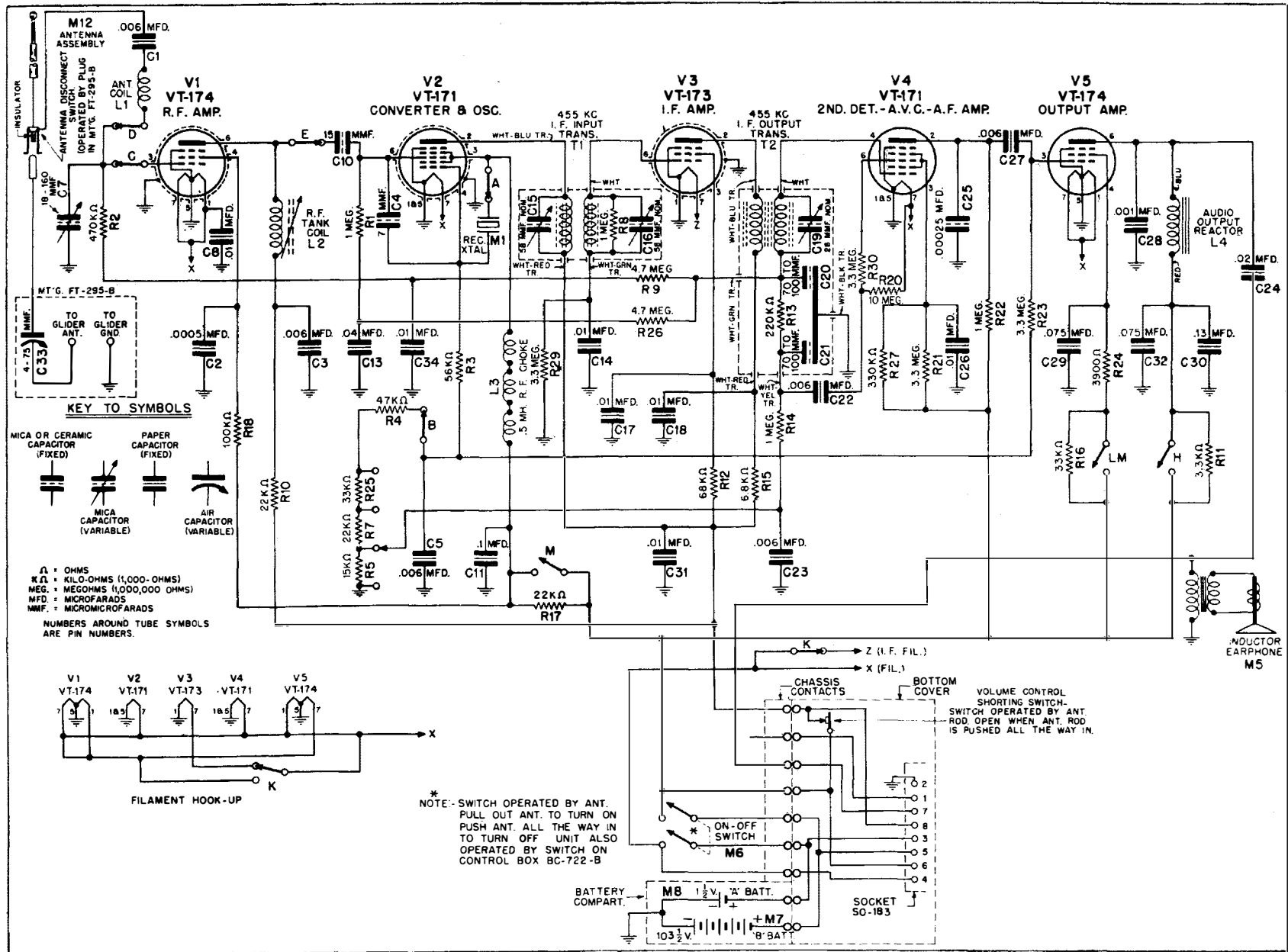

FIG. 25. FUNCTIONAL DIAGRAM OF RECEIVER BC-721-B

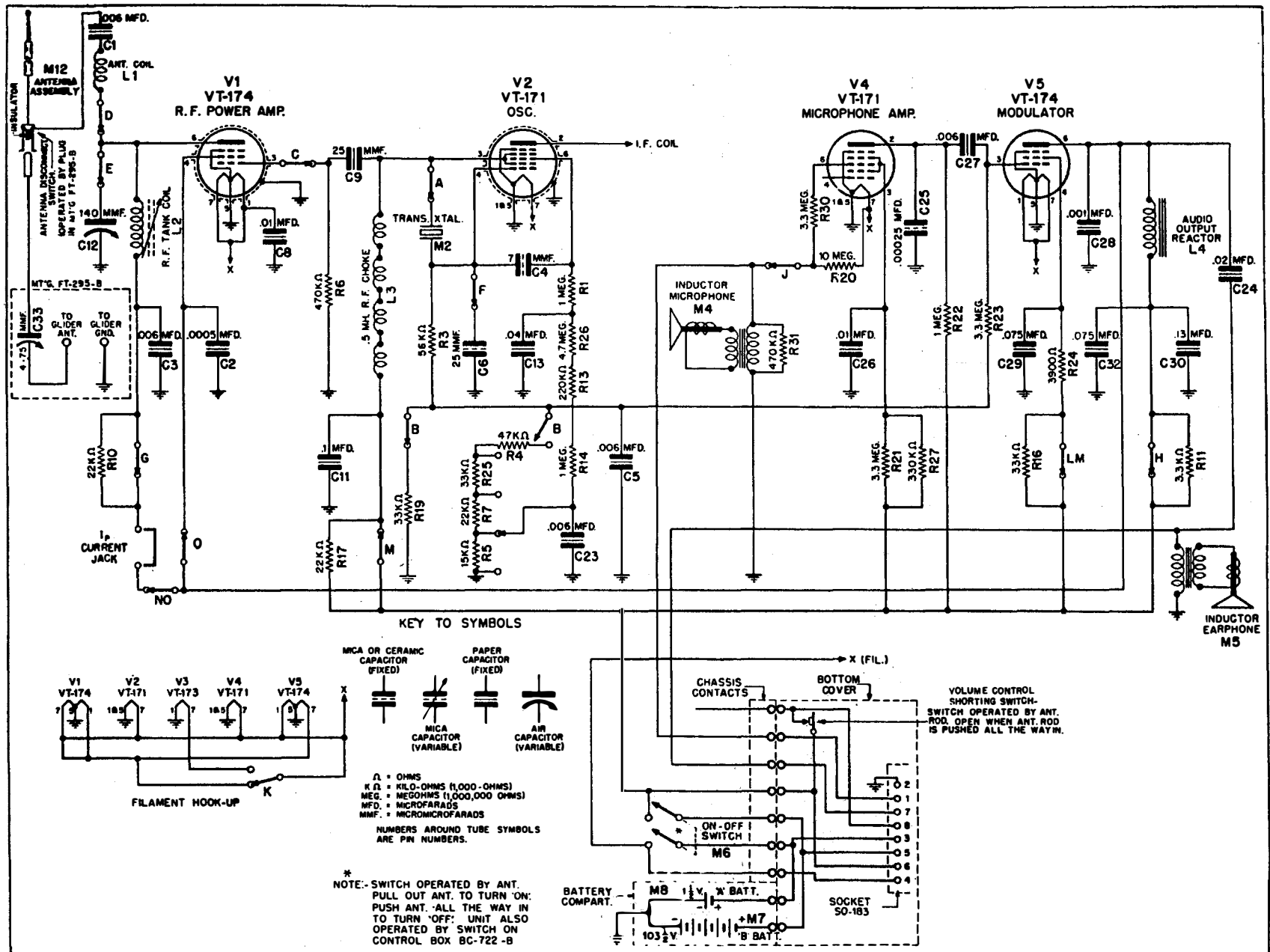

FIG. 26. FUNCTIONAL DIAGRAM OF TRANSMITTER BC-721-B

